

Wadkin

~~117~~ C686
No. 432
Wadkin

WOODWORKING MACHINERY

C686

~~A 12~~
STORES OFFICER,
No. 2 Explosives & Filling Factory,
Salisbury, South Australia.



Wadkin



STORES OFFICER,
No. 2 Explosives & Filling Factory,
Salisbury, South Australia.

Wadkin

WOODWORKING MACHINERY



Wadkin Ltd.

Green Lane Works, Leicester, England.

Governing Director: J. Holland Goddard. Directors: L. Austin; C. H. Morris; A. Priestnall.

Telephones: Leicester 27114 (3 lines)
Telegrams:
"Woodworker — phone — Leicester"

Cables: "Woodworker, Leicester"
Codes: A.B.C. 5th and 6th Editions
Lieber's and Marconi International

LONDON OFFICE: 89 KINGSWAY, W.C.2.

TELEPHONE: HOLBORN 4532

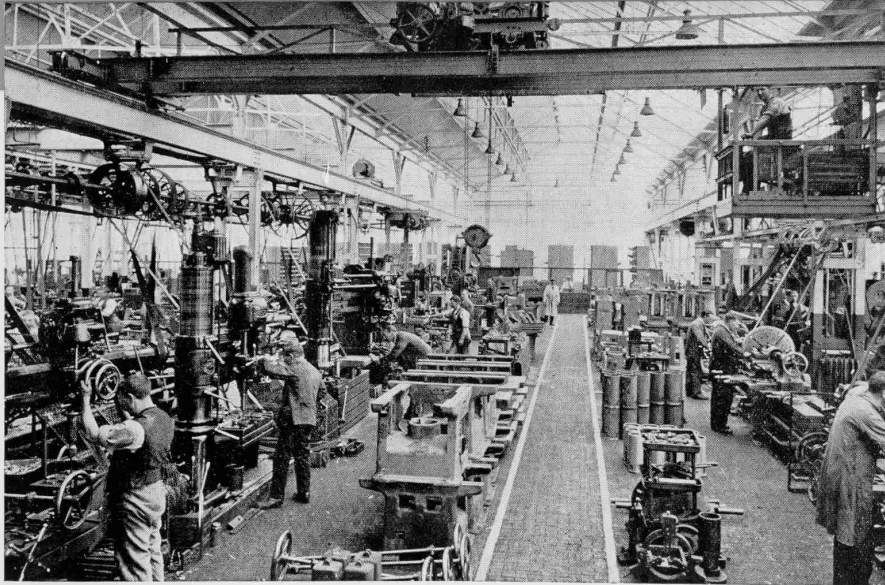

Green Lane Works, Leicester, the home of Wadkin Woodworking Machinery, are recognised as one of the best equipped works of their kind in the World.

The view above shows one of six bays comprising the main engineering shops. Precision standards of accuracy are enforced throughout all machining and erecting processes, and before leaving the works all machines must pass rigid mechanical and electrical tests, also extended running tests at the hands of a staff of Woodworking Machinists.

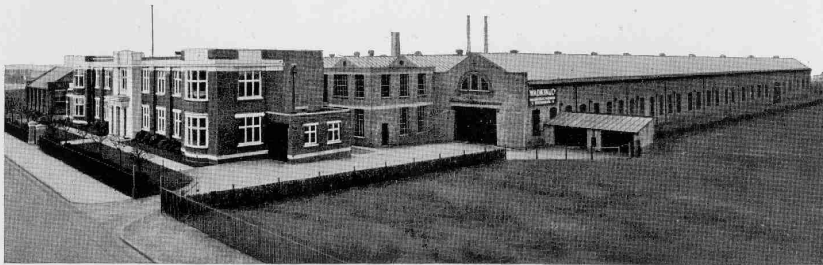

Introduction.



This Abridged Catalogue is intended to give only a brief outline of the more common types of Wadkin machines.

More comprehensive information in the form of Booklets and Circulars dealing with each machine individually, will be sent on request.

Other types of machines are available in addition to those illustrated. The complete range includes practically all types of machines for handling timber from the plank stage.

Whatever your needs, we shall be pleased to advise on the best machines for your purpose and provide complete specifications.

Electric Cross Cutting and Trenching Machine C.C.

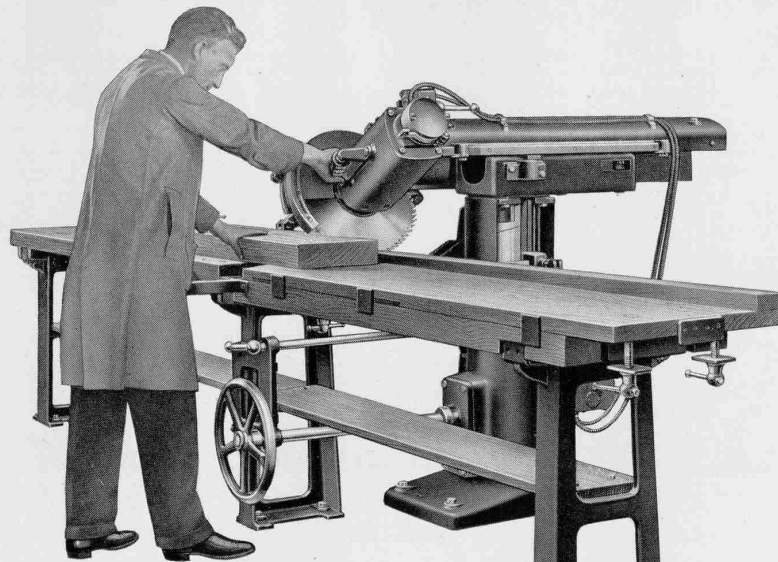

This machine not only forms a fast operating cross cut saw for either straight, angular or compound angular cutting, but is equally successful as a trenching and grooving machine.

The Saw has rise and fall, canting and swivelling movements, each provided with locking devices.

Saw or Grooving Head is carried directly on the motor shaft. Saw carriage is aluminium and moves on ball bearing rollers on hardened and ground steel circular tracks.

Carriage is returned by spring action, and pneumatic buffer prevents rebound. Brake is fitted to saw spindle.

Table may be of wood constructed by purchaser, or all metal table can be supplied.

Dimensions and Capacities.

	Model C.C.1	Model C.C.2
Diameter of saw	18"	18"
Will cut off between	20" × 4½" and 25" × 1"	28" × 4½" and 33" × 1"
Will groove up to 2½" × 1⅝" deep in material	17¾" wide	25¾" wide
Horse power of motor	5	5

Electric Cross Cutting and Trenching Machine C.D.

This machine has rise and fall, also swivelling motions for straight or angular cross cutting and trenching.

The Motor is underslung mounted to conserve space, and is provided with brake.

Saw Carriage is of aluminium and moves on ball bearing rollers on hardened and ground steel circular tracks.

All principal angles on swivelling motion are marked and positively located.

Saw Carriage has spring return motion and is fitted with pneumatic buffer.

Table may be of wood, constructed by purchaser, or an all metal table supplied.

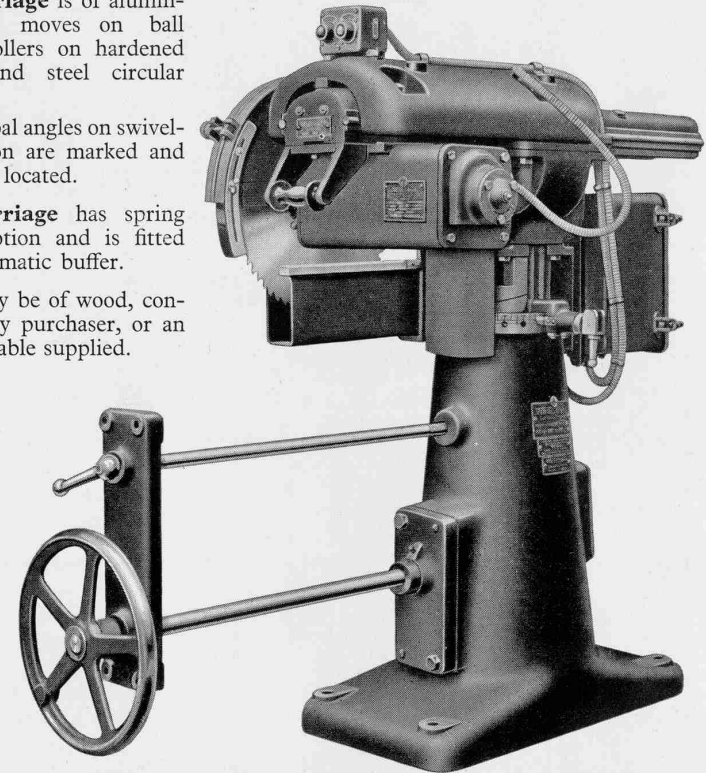

Dimensions and Capacities.

	Model C.D.1	Model C.D.2	Model C.D.3
Diameter of saw	18"	18"	24"
Will cut off between	14" × 4½" and 18" × 1"	20" × 4½" and 24" × 1"	16" × 7" and 21¾" × 4½"
Will groove up to 2½" × 1⅝" in material	10¾" wide	16¾" wide	not available
Horse power of motor	5	5	6

Electric Straight Line Cross Cut C.F.

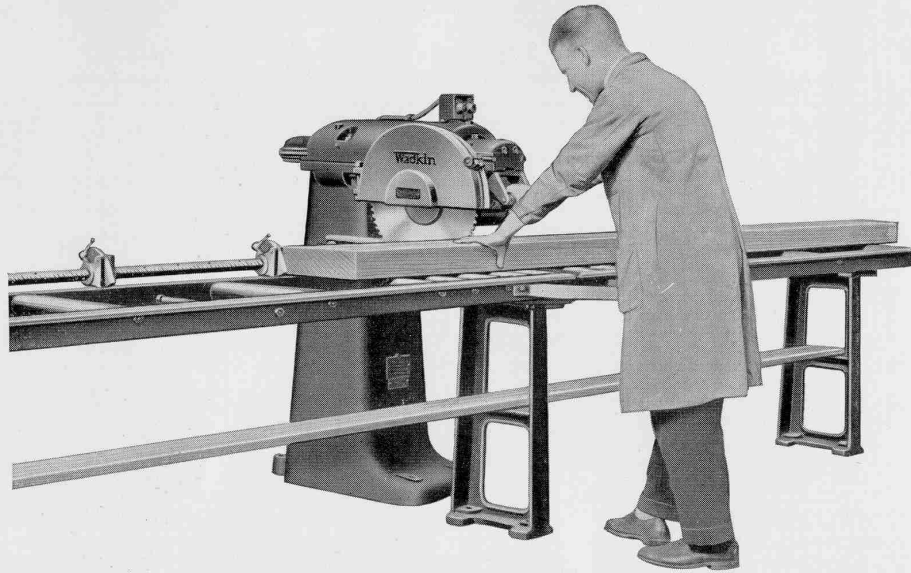

This is a powerful straight line machine for straight cross cutting.

The Saw Carriage is of aluminium and moves on ball bearing rollers on hardened and ground steel circular tracks.

Return motion is by spring action, and a pneumatic buffer prevents rebound.

Motor is underslung mounted to conserve space.

An all metal table as shown is recommended, but this may be of wood, constructed by purchaser.

Dimensions and Capacities.

	Model C.F.1	Model C.F.2	Model C.F.3
Diam. of saw ..	18"	18"	24"
Will cut off ..	14" × 4½"	20" × 4½"	16" × 7"
Horse power ..	5	5	6

Wadkin

14" Universal Overhead Saw C.K.

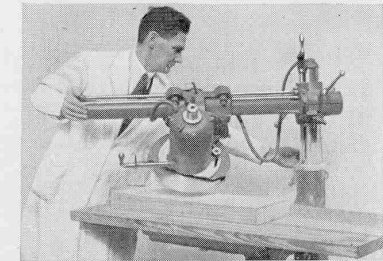
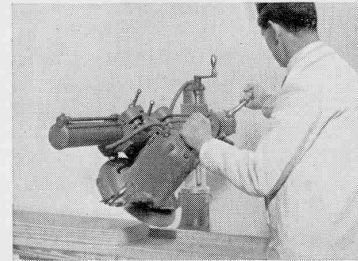

Arm rotates 45° and column swivels through 180° for compound angular cutting.

This machine has a wide scope of working with both saw and trenching head.

The Arm and Column adjust as shown above. In addition arm has rise and fall motion, and motor can be swivelled to bring the saw parallel with the fence.

All Motors have locks and principal angles are positively located.

Saw Carriage moves on ball bearing rollers on renewable steel runways.

Table is of wood and easily made by purchaser to suit his requirements.

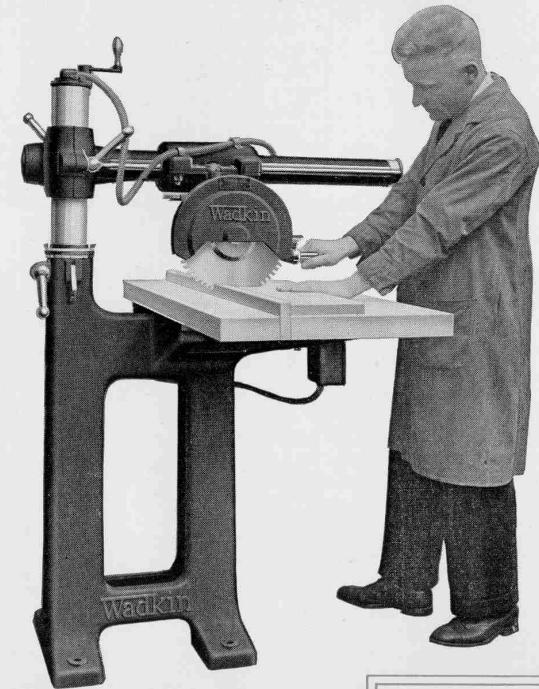

Dimensions and Capacities.

Max. diam. of saw ..	14"
Width will cross cut with arm at 90° ..	18"
Max. depth of cut ..	3"
Max. depth will trench ..	1"
Horse power ..	2
Floor space ..	4' 9" × 3' 9"

Wadkin

Electric Snipper Cross Cut Saw C.L.



This machine provides an amazingly simple, safe and speedy method of cutting anything up to 6" x 2".

Saw Carriage is pivoted from the main column, and is brought into the cut either by hand lever or treadle.

The Carriage is spring counterbalanced and a pneumatic buffer cushions the return stroke.

Motor is mounted on the column and is independent of pivoting motion.

The machine is arranged to take a table made by the purchaser. Fence is provided, and cutting off gauge as shown, can be supplied.

Dimensions and Capacities.

	C.L.1	C.L.2
Max. size of saw ..	12"	14"
Max. section of cut ..	4" x 2"	6" x 2"
Longest length cut off using standard bar ..	4' 0"	4' 0"
Longest length cut off with specially long bar	7' 3"	7' 3"
Horse power of motor	2	2

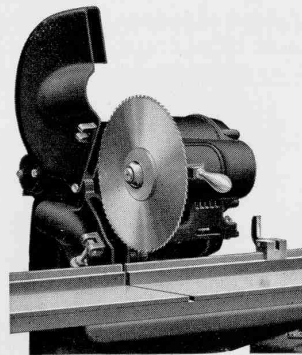

Guard swings clear for getting at the saw. When down it completely covers the saw.

Wadkin

24" and 32" Pendulum Cross Cut Saws A.Y.

This is a well known type of machine for straight cross cutting.

The Main Frame is in one piece, and designed to give strength without undue weight. The frame swings on a fixed shaft, on which the main driving pulley is mounted.

Electric Drive is by means of a motor fixed to the overhead base plate, and drives to the main pulley by means of multiple vee belts.

Saw Spindle revolves in ball bearings.

Guards to both saw and belt are provided, the former being arranged with hinged front plate.

Table may be of wood constructed by purchaser, or alternatively the all metal type shown may be supplied.

Belt drive is also available.

Dimensions and Capacities.

	24" A.Y.	32" A.Y.
Maximum size of saw	24"	32"
Approx. size timber cross cut ..	14" x 7"	24" x 9"
Approx. distance from beam to centre of saw spindle (electric) ..	6' 10"	6' 10"
Horse power required	4	5

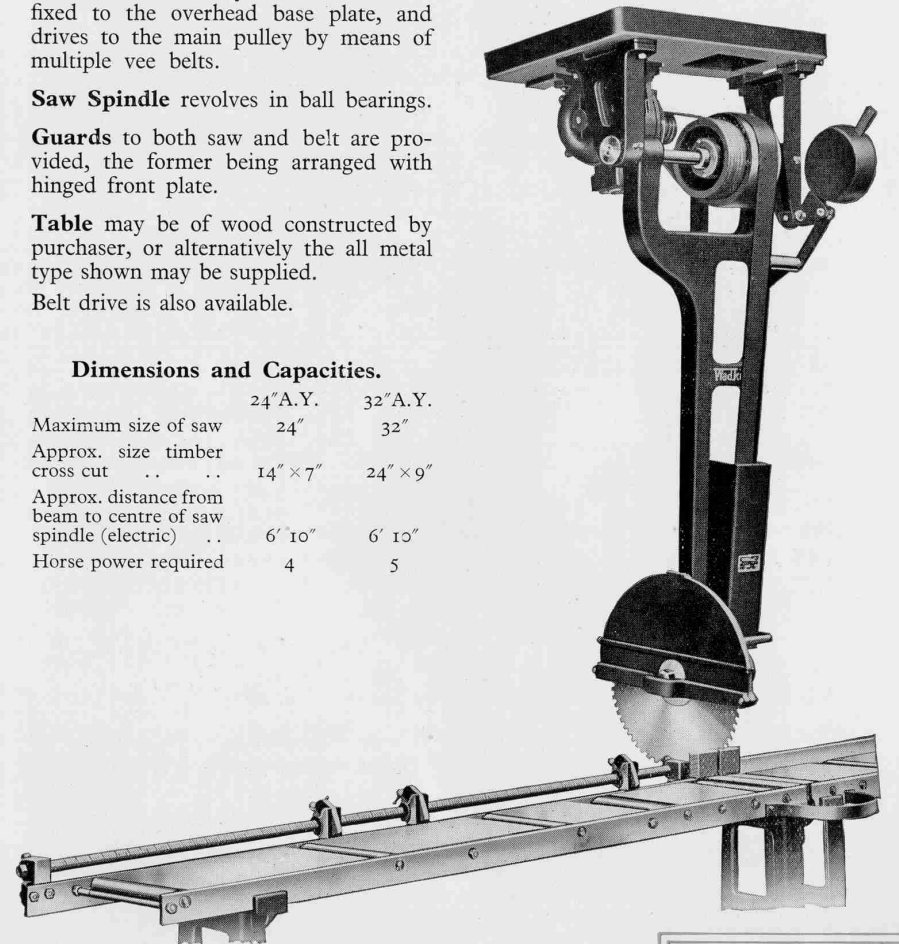

Wadkin

20" Circular Saw Bench with rising and falling table S.O.

The Table has rising and falling movement on a circular slide. It is grooved to take fences and has a removable plate to allow grooving heads to be used.

The Saw Spindle runs in ball bearings and the back end is bored to take augers.

The Fence has quick and fine screw adjustment. It cants 45 degrees and front plate is adjustable.

The Saw is totally enclosed below the table by a hood with a nozzle for discharging the sawdust behind the machine.

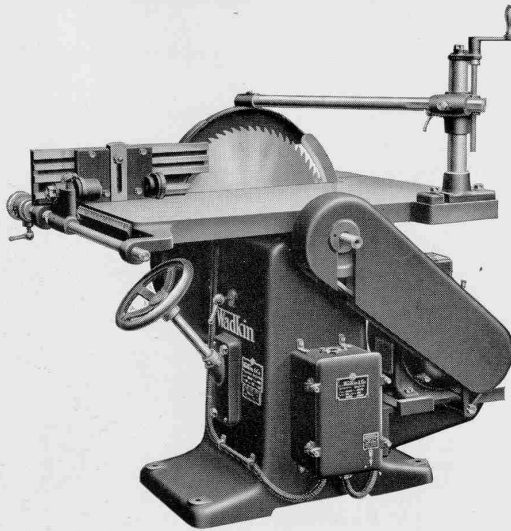

Drive. Electric drive is shown above. When belt driven, fast and loose pulleys are provided, the loose pulley being mounted on a separate sleeve. Belt striking gear is self-locking.

Dimensions and Capacities.

Max. size of saw	20"
Max. depth of cut	7"
Size of table	3' 4" x 2' 6"
Max. distance between saw and fence	18"
Distance between front of table and saw	11 1/4"
Rise and fall of table	5"
Will take grooving heads up to	1 1/2" wide
Mouldings up to	2 1/2"
Horse power	5
Floor space (electric)	4' 0" x 3' 3"

26", 32" and 36" Circular Saw Benches with rising and falling or fixed tables. S.P. and S.R.

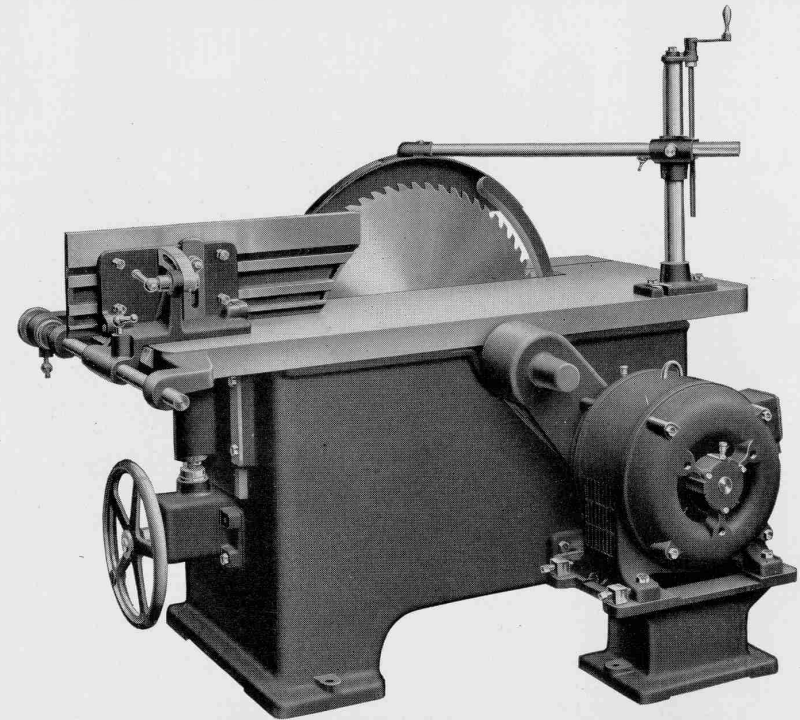

The Table is specially wide between the front edge and the saw. It is fitted with a removable gap plate, and with a scale for setting the heavy canting fence. Table is grooved to receive a cross cutting fence. Fence has both quick and fine screw adjustment.

Saw Spindle revolves on ball bearings, and is prepared to take boring bits.

Drive. The arrangement of electric drive is as shown.

When Belt Driven fast and loose pulleys and self locking shifting gear are provided.

On Rising and Falling Table Machines, table is controlled by screws totally enclosed and mounted outside the main frame to ensure ease of operation and freedom from binding.

Dimensions and Capacities.

	26"	32"	36"
Max. depth of cut	9"	12"	14"
Size of table	4' 8" x 2' 6"	5' 2" x 2' 6"	5' 6" x 2' 6"
Rise and fall of table	6"	6"	6"
Max. distance between saw and fence	15 1/2"	15 1/2"	15 1/2"
Floor space (vee belt electric)	6' 9" x 3' 4"	7' 0" x 3' 4"	7' 3" x 3' 4"
Horse power	10	12	15

Electric Straight Line Edger P.U. with under-cut saw.

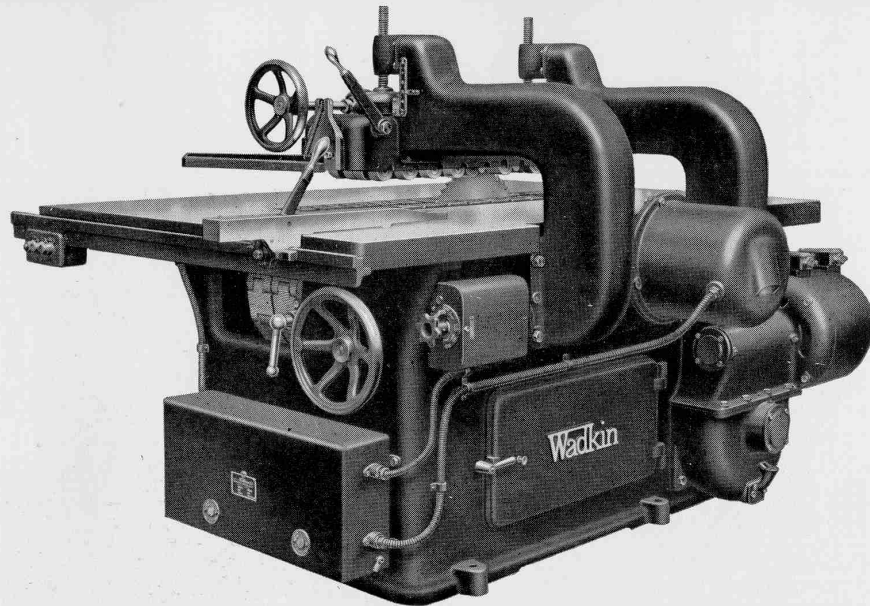

The value of this machine lies in its ability to rip stock in a dead straight line at a high rate of feed.

The Saw is perfectly supported in the main frame which makes it impossible for it to get out of alignment. It is raised and lowered by handwheel and driven by motor built directly on the saw spindle.

The Chain Feed is driven by a variable speed motor. The chain and chain bed are made of a special nickel cast iron to ensure long life. A unique system of multiple grooves in both the chain and chain bed, ensures that the chain is guided in a dead straight path, and guarantees permanent accuracy. With the saw cutting in a normal downward direction, a drive to the rolls is unnecessary. The top rollers are housed in a sturdy casting which is raised and lowered by screw motion.

The Table is unusually large and will admit up to 30" on the right of the saw. A counter-balanced safety table is provided at the end of the chain and a fence and setting scale is provided.

Dimensions and Capacities.

Max. depth of cut 4"	Timber above 24" up to 30"
Max. diam. of saw 17"	can be sawn up to 1 3/4" deep
Max. width of timber on right	Rates of feed in feet per min.
of saw when cutting 4" deep 24"	50, 75, 100 & 150
	Size of table 6' 9" x 4' 11 1/2"

Wadkin

36" Under Driven Roller Feed Saw P.T.

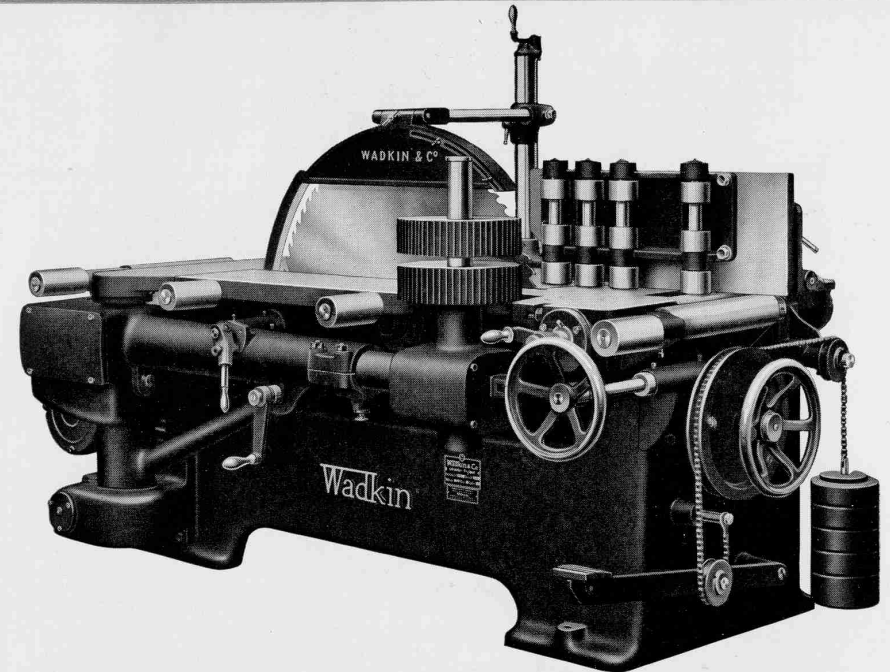

For resawing deals into boards or for bevel sawing weather boarding, etc.

The Table is fitted with anti-friction rollers, and front portion can be drawn back for getting at the saw.

The Saw Spindle runs in three heavy ball bearings, including an outer bearing supported on a pedestal.

The Fence is adjustable across the table by screw motion. It is provided with anti-friction rollers adjustable in height. The fence cants up to 45 degrees for bevel sawing, and front plate adjusts horizontally.

The Feed Rollers are carried on a radial arm, and can be adjusted horizontally and vertically. They can also be canted up to 15 degrees in either direction, or inverted leaving the table clear. Six rates of feed are provided.

Electric Drive is by multiple vee belts from motor placed at the outfeed end of the machine.

Belt Driven machine is provided with fast and loose pulleys and self-locking striking gear.

Dimensions and Capacities.

Max. size of saw 36"	Rates of feed in feet
Max. depth of cut 13 1/4"	per min. 36, 54, 62, 93, 103, 154
Size of table 5' 6" x 2' 9"	Horse power 25
Max. distance between saw and	Floor space vee belt
power feed rollers 10 1/2"	(electric) 9' 0" x 5' 4"
Max. distance between saw and fence 12"	

Wadkin

Electric 18" Canting Spindle Dimension Saw P.K.

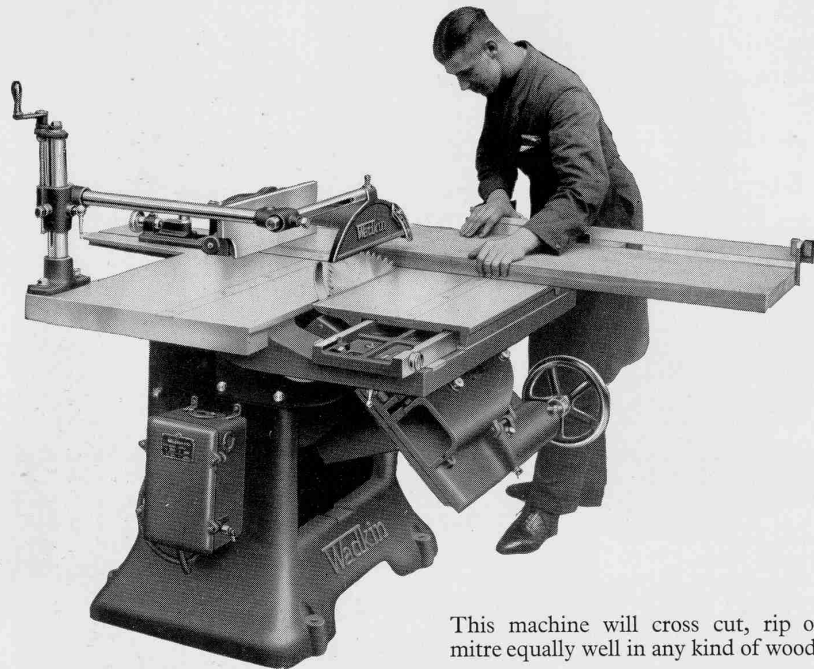

This machine will cross cut, rip or mitre equally well in any kind of wood.

The Saw cants up to 45 degrees, the table remaining always in the horizontal position. The saw spindle has also vertical adjustment for rebating, trenching, etc. **The Table** is marked out with scales for convenience in setting the fences. Front portion moves on ball bearing rollers.

The sliding table has also a movement away from the main table to give the necessary gap for grooving saws, etc.

Three fences are supplied with the machine; a ripping fence with canting and adjustable front plate and fine screw adjustment. A cutting-off fence arranged to swivel 180 degrees, also a universal double mitre fence, both provided with stops.

The Motor is mounted directly on the saw spindle.

An extension cross cutting table with stops for cutting off material 48" long, can be supplied.

Dimensions and Capacities.

Diameter of saw .. 18"	Will rip up to .. 22" wide
Max. depth of cut .. 4"	Size of table 3' 8" x 3' 2"
Will cross cut 30" wide 4" deep	Floor space 3' 8" x 4' 6"
or 36" wide 1" deep	Horse power of motor .. 4
Length of material cut off	
using stops on fences .. 36"	

Wadkin

30" and 36" Band Sawing Machines D.R.

Absolute rigidity is ensured in these machines by a heavy frame, rigid mounting of the table on a quadrant, and an improved motor mounting close up to the pulley.

The Saw Wheels are of the disc type to ensure strength, stability and freedom from draught when running.

Saw Tensioning is controlled by a spring and an indicator registers the correct tension for any width of saw. Tracking device is provided.

Saw Guide above table is of the ball bearing type and counterbalanced.

Hinged metal guards give instant access to saw.

Belt driven models are also available.

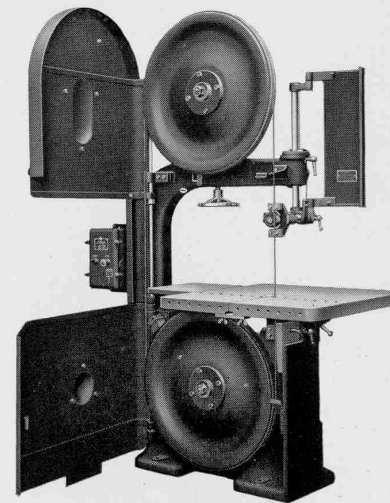
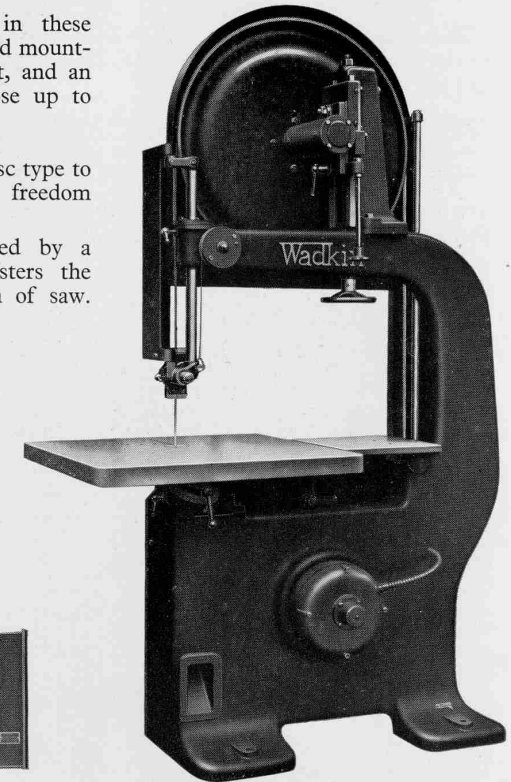

Dimensions and Capacities.

Diameter of saw wheels ..	30"	36"
Max. width of saw ..	1½"	1½"
Max. length of saw ..	17' 0"	20' 0"
Minimum length of saw ..	16' 0"	19' 0"
Depth of cut under saw guide ..	14"	18½"
Table cants 45° to right, 5° to left		
Horse power ..	3	4
Floor space (electric) ..	4' 8" x 2' 10"	5' 6" x 3' 2"

Wadkin

Electric High Speed Planing and Moulding Machines F.C. 4"×4", 7"×4".

These machines differ in many important respects from any other British built machine. In the Wadkin design the FIRST HEAD is placed above the stock, and the last head is a bottom head.

By this arrangement the work is produced more accurately to shape and pattern. In addition set ups can be made faster due to the short compact design and the simple pressure system, that only this arrangement of heads will allow.

The unique design also enables these machines to produce work with four heads that would normally require at least a five head machine, with bottom head first.

The Feed is by two top rolls and patent rolling chain bed.

Drive is by reversible type B.T.H. motor mounted on an adjustable slide and equipped with a variable speed pulley. Power is transmitted by a "Reeves" type belt. The Cutterhead Spindles are all of the same diameter, and heads are interchangeable.

The Spindles revolve on two ball bearings located in one cylindrical housing between cutterhead and motor, the section of the spindle between the bearings being of enlarged section to give increased rigidity.

The Motors are mounted on the spindles and consist of B.T.H. Rotor and Stator units. The feed motor is a standard 2 speed industrial type.

The Top and Bottom Heads have vertical also horizontal adjustment by screw motion. Top Head Chipbreaker moves with the head and is also adjustable to suit varying cutter diameters.

Side Heads have vertical also "in and out" adjustments. On the 7" machine

both side heads can be arranged to cant inwards. Side Head Chipbreaker is attached to the front side table unit and automatically moves with the side head adjustment.

The Table is unbroken throughout its entire length. The table after the bottom head, is attached to the bottom head unit and adjusts with the head.

The entire back table swings down and away.

Top Pressures are simple, rigid and easily adjustable. Top head pressure is attached to the head and moves with it. Independent adjustment is also provided.

Fences are adjustable in two directions.

Control Gear is of the automatic contactor type allowing for individual control to each motor also feed reverse. Inching button is provided at outfeed end and a master stop button at both ends.

Frequency Changer is supplied with the machine.

Dimensions and Capacities.

Maximum size	4" × 4"	7" × 4"
Speed of cutterheads	7500 r.p.m.	6000 r.p.m.
Horse power. Top and bottom heads	6	10
Horse power. Side heads	6	7½
Horse power feed motor	3	5
Top roll diameters	5"	8"
Feed speeds in feet per minute	30 to 90	30 to 145
Overall length	6' 9½"	9' 3"

Wadkin

Electric High Speed Planing and Moulding Machines F.C. 4"×4", 7"×4".

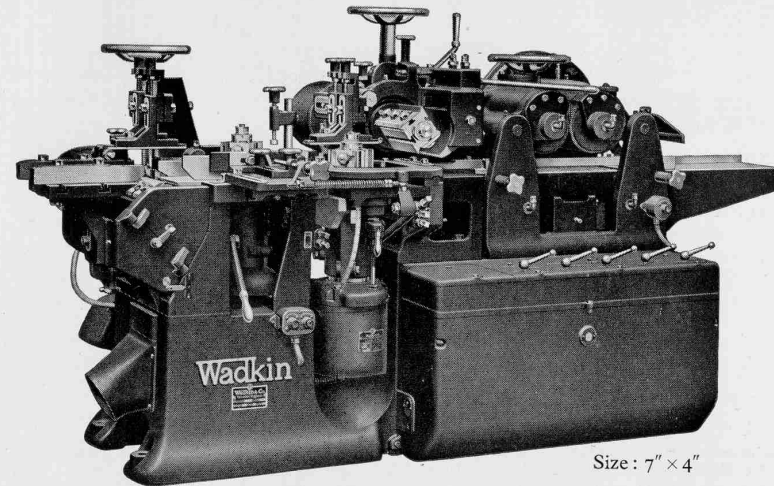

Size : 7" × 4"

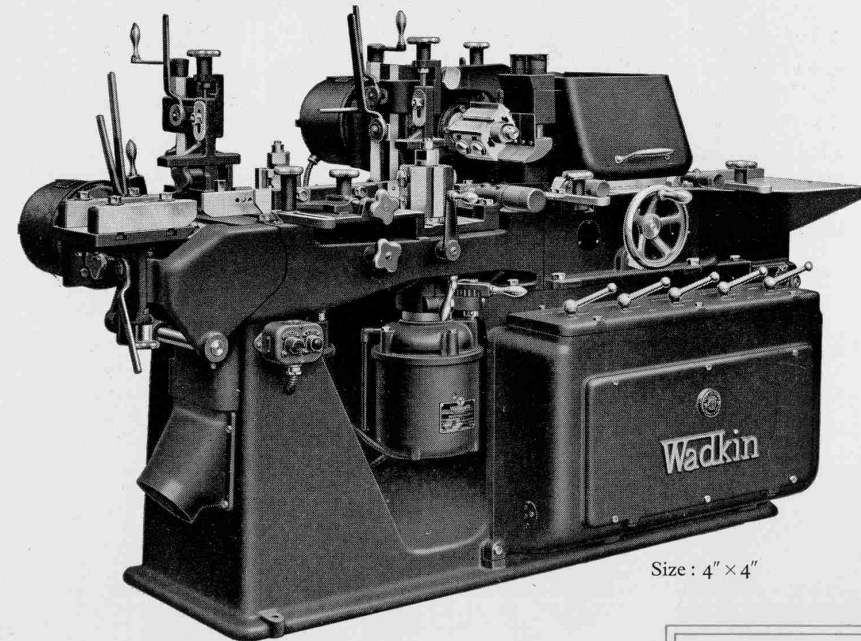

Size : 4" × 4"

Wadkin

12" and 16" Surface Planers and Jointers R.D.

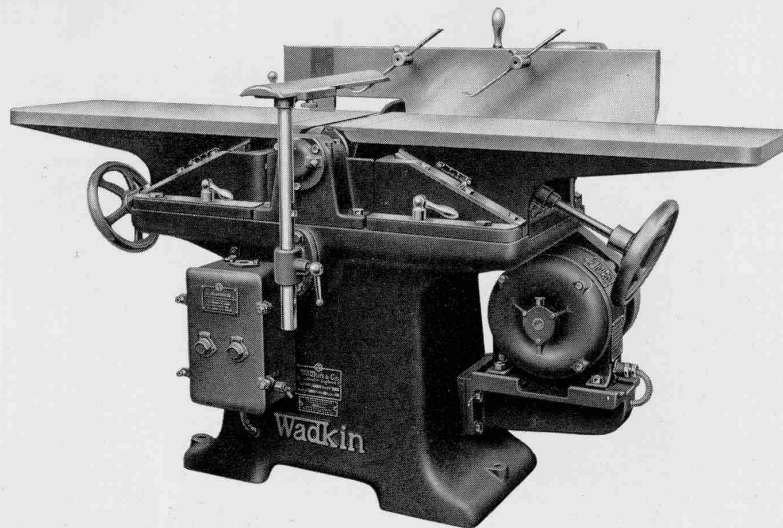

For surfacing all kinds of timber, making glue joints, rebating, chamfering, tonguing and grooving, moulding, etc.

The Tables have draw out also rising and falling motion, and edges adjacent to the block have steel lips.

The Fence cants 45° and is adjustable across the table by handwheel and rack motion. Table extension enables fence to be set back and full width of cutters used.

The Cutterblock is of the safety circular type, and incorporates a unique screw knife setting device. Moulding irons can be attached without upsetting the ordinary planing knives.

A Chute is embodied in the main frame to discharge the chips clear of the machine.

Electric Drive is by endless vee belts from motor, as shown above. For belt drive, countershaft is supplied.

Dimensions and Capacities.

	12" Model R.D.	16" Model R.D.
Surfacing capacity	12"	16"
Max. depth of cut	1"	1"
Max. depth of rebate in any width	3/8"	3/8"
Length of tables	6' 0"	6' 0"
Speed of cutterblock in r.p.m. ...	4000	4000
Floor space	6' 0" x 2' 8"	6' 0" x 3' 0"

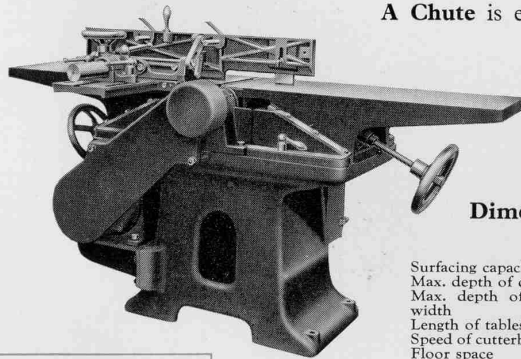

6" and 9" Surface Planers and Jointers R.A. and R.B.

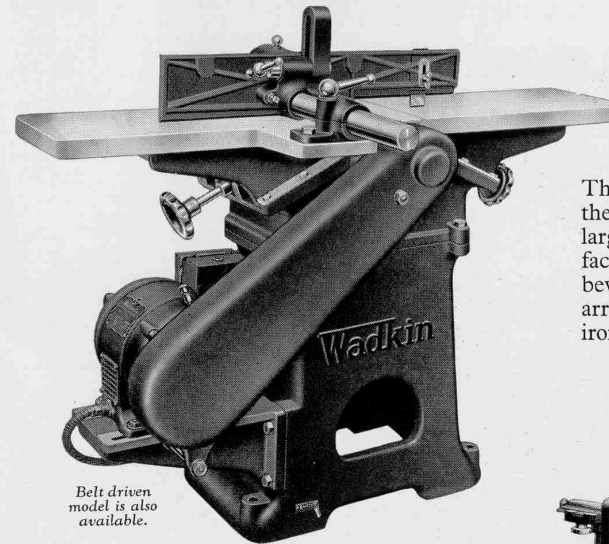

Belt driven model is also available.

These machines are built on the same sturdy lines as the larger ones. Both will do surfacing, rebating, chamfering, bevelling, and the 9" model is arranged to take moulding irons.

The Tables are long and have steel lips. Tables rise and fall by screw motion, and on 9" machine draw out motion is provided.

The Fence cants 45°.

The Safety Circular Cutterblock carries two thin knives and revolves in ball bearings.

A Chute is embodied in the main frame to discharge chips.

The Drive is by endless vee belt from motor as illustrated.

Dimensions and Capacities.

Surfacing capacity	6"	9"
Max. depth of cut ..	1/2"	1"
Max. depth of rebate in any width ..	3/8"	3/8"
Length of tables ..	3' 6"	5' 0"
Speed of cutterblock	5000 r.p.m.	4000 r.p.m.
Horse power ..	1	2
Floor space ..	3' 6" x 2' 2"	4' 6" x 2' 9"

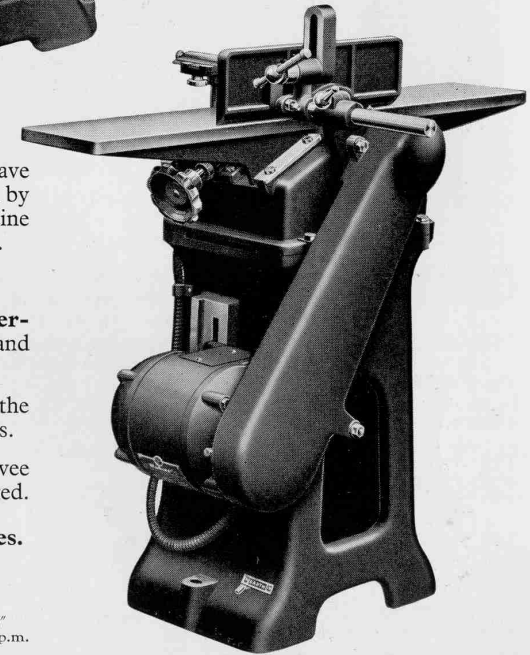

Wadkin

Wadkin

30" Panel Planing and Thicknessing Machine R.J. with sectional feed rollers.

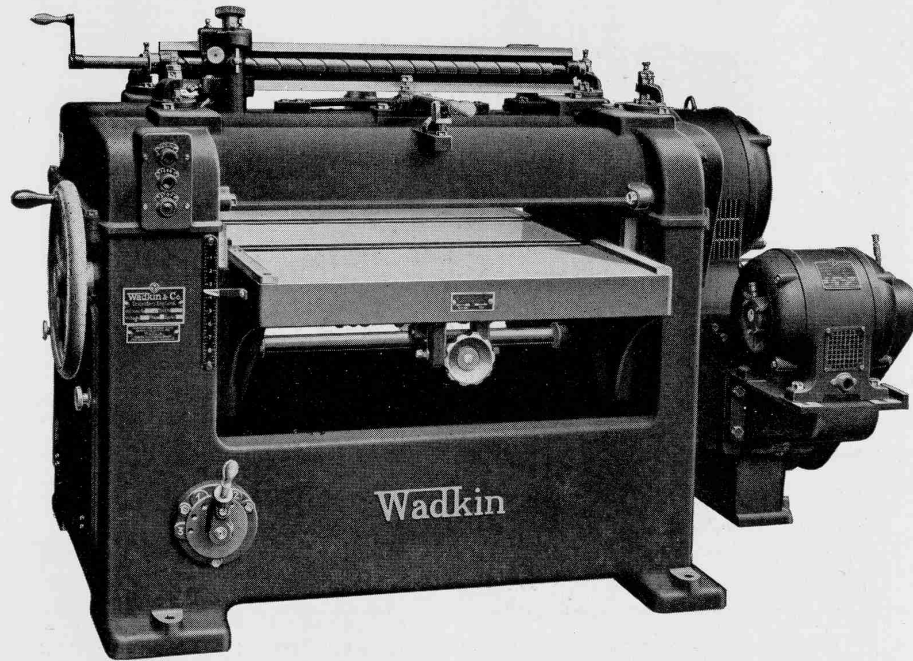

For thicknessing timber to exact dimension. The Sectional feed enables a high rate of output to be obtained when working narrow material.

Table rises and falls 9" by handwheel and screw motion, and all mechanism is fully protected.

The Feed Rolls are all power driven. Top front roller is of the sectional type. Each section is controlled by 8 springs and is dust-tight. Feed mechanism embodies oil bath gear box. Table rollers revolve in ball bearings and both have quick vertical adjustment.

The Sectional Chipbreaker is mounted concentrically with the block to retain the same relative distance from the knives in any position. Both chipbreaker and feed rolls are of a special dust-tight design to avoid all possibility of sticking.

The Safety Circular Cutterblock is of the 4 knife wedge type. Screws are provided for each knife for quick and accurate setting.

Electric Drive. Both cutterblock and feed are driven by separate motors transmitting power by endless vee belts. Belt driven machine is available.

Dimensions and Capacities.

Max. size of timber planed ..	30" x 9"
Speed of cutterblock ..	4000 r.p.m.
Diameter of cutterblock ..	5'
Diameter of feed rolls ..	5'
Rates of feed in ft. per min. ..	27, 37, 57
Horse power cutterblock ..	12½
Horse power feed ..	2
Floor space (electric) ..	4' 3" x 6' 4"

20" and 24" Panel Planing and Thicknessing Machines R.E. with plain feed rollers.

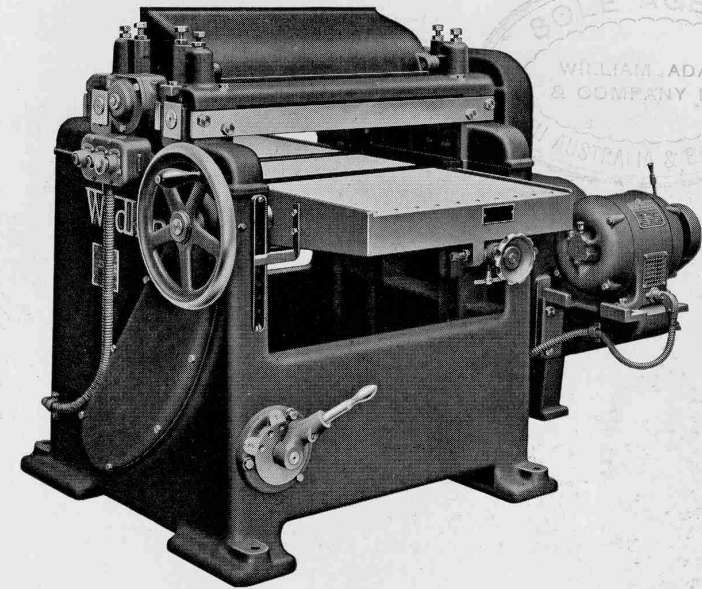

These machines are guaranteed to produce the finest class of planing, thicknessing, moulding, etc., in hard or soft woods.

The Main Frame and table are exceptionally robust to eliminate vibration. The table rises and falls 9" by handwheel and screw motion, and all raising and lowering mechanism is protected from dust.

The Power Feed Rollers are self oiling and driven by heavy chain from gear box. Table rollers revolve in ball bearings and are provided with quick vertical adjustment.

The Square Cutterblock revolves in heavy type ball bearings. Moulding cutters can be used without upsetting the planing irons.

The Pressure Bars and feed rollers are controlled by adjustable springs.

Electric Drive is by endless vee belts from separate motors built on to the machine. Belt drive is also available.

Dimensions and Capacities.

Max. size of timber planed ..	20" x 9"	24" x 9"
Speed of cutterblock ..	4200 r.p.m.	4200 r.p.m.
Rates of feed in feet per minute ..	20, 30, 46	20, 30, 46
Horse power for cutterblock ..	5	7½
Horse power for feed ..	1	2
Floor space (electric) ..	4' 10" x 4' 0"	5' 3" x 4' 0"

Wadkin

Wadkin

20" and 24" Surface Planing and Thicknessing Machines R.M.

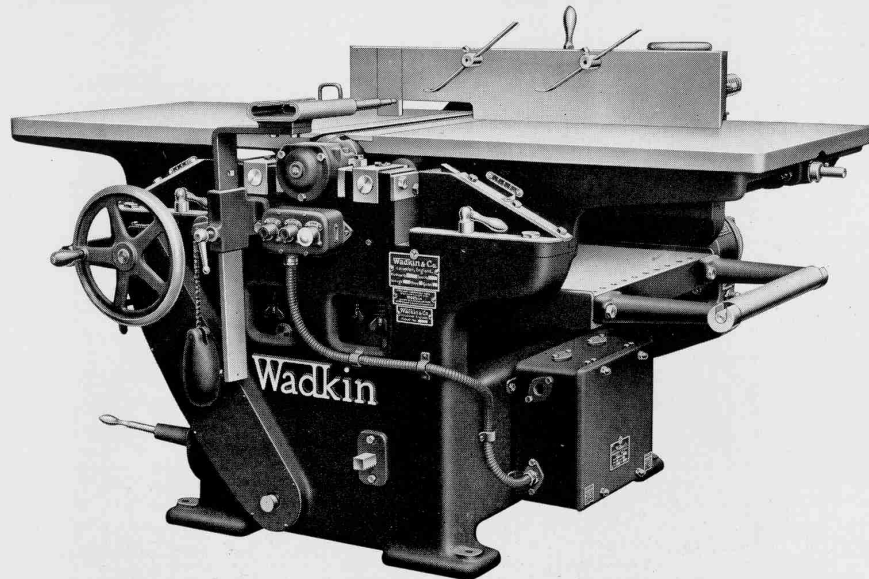

Surfacing Tables are ground dead true and have draw out motion also rise and fall motion. Both tables are fitted with steel lips to prevent chipping. The tables are specially arranged to enable rebating to be done and front surfacing table may be arranged to cant by screw motion for taper planing, for pattern shop work.

Fence cants 45° and is adjustable across the table by rack motion.

The Thicknessing Table Rollers revolve in ball bearings and have quick vertical adjustment. Carrier rollers are fitted for long work. All mechanism for the rising and falling motion of table is protected against dust.

The 2 Knife Circular Cutterblock runs in heavy ball bearings and embodies a unique knife-setting arrangement. It is arranged to take moulding irons without upsetting the planing knives.

The Feed. Three rates of feed are provided by means of a gear box. All gearing runs in oil. The feed rollers and pressure bars are controlled by adjustable springs and are provided with stops to prevent them being lifted into the cutters.

Electric Drive. Both cutterblock and feed motion are driven by separate motors, and transmitting power by endless vee belts.

Belt Drive. Countershaft with fast and loose pulleys and striking gear is provided.

Dimensions and Capacities.

	20" Model	24" Model
Thicknessing capacity	20" x 9"	24" x 9"
Surfacing capacity	22"	26"
Maximum depth of cut	$\frac{3}{8}$ "	$\frac{7}{8}$ "
Length of surfacing tables	6' 1"	6' 1"
Length between carrier rolls in thick-		
nessing table	5' 5 $\frac{1}{2}$ "	5' 5 $\frac{1}{2}$ "
Speed of cutterblock in r.p.m.	4200	4200
Cutting circle of cutterblock	5"	5"
Rates of feed in feet per minute	20, 30, 46	20, 30, 46
Horse power of cutterblock motor	5	5
Horse power of feed motor	1	1
Floor space (electric drive, approx.)	6' 1" x 5' 0"	6' 1" x 5' 4"

Electric Spindle Moulder and Shaper E.P.

These machines are designed for every class of spindle work. They are entirely self-contained, and the method of electric driving enables speeds up to 6000 r.p.m. to be obtained without the need for a frequency changer.

The Spindle runs on ball bearings, and it is provided with a locking device and brake. The spindle has rise and fall movement of 6" by screw.

The drive to the spindle is by endless vee belts from motor. Both motor and main spindle rise and fall together, giving constant position of the drive irrespective of height of spindle. Standard speeds are 6000 and 4500 r.p.m., or if preferred 4500 and 3000. A belt driven machine is also available.

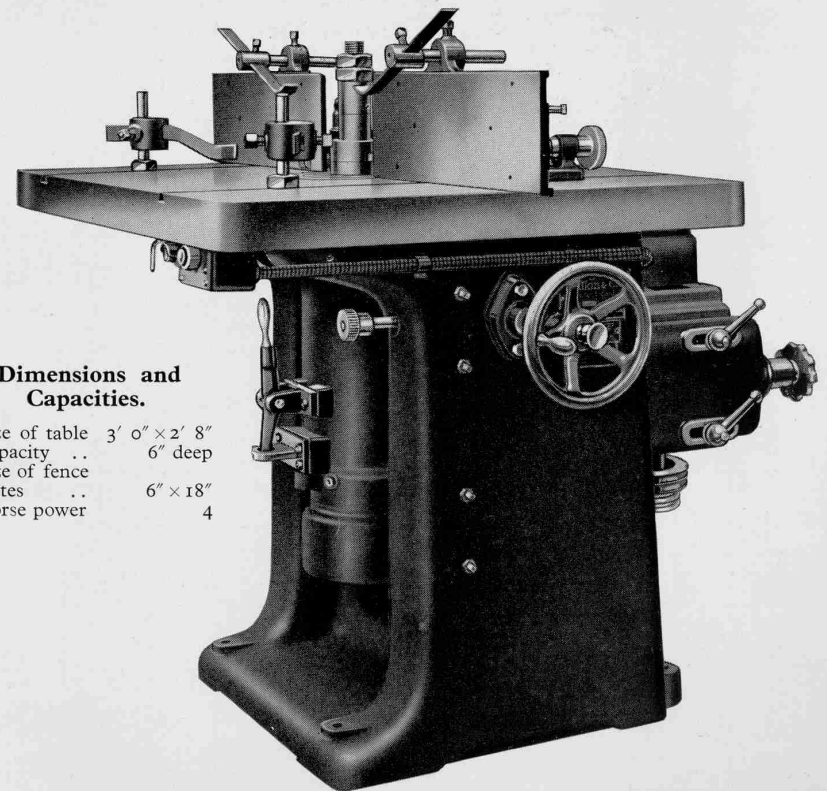

Dimensions and Capacities.

Size of table	3' 0" x 2' 8"
Capacity ..	6" deep
Size of fence plates ..	6" x 18"
Horse power	4

Wadkin

Wadkin

Electric Combined Chain and Chisel Mortiser M.F.

The Table has longitudinal, transverse and rise and fall movements, operated by handwheels. Provision is made to take an automatic setting-out attachment.

The Chain Headstock has built in motor and is operated by hand lever. The chain can be set either dead in line with the chisel, or out of line for making offset mortises. An exhaust fan and adjustable chipbreaker is fitted.

The Hollow Chisel Headstock has the motor built in. It incorporates a blower for keeping the face of the work clear of chips.

Adjustable Depth Stops are provided on both chain and chisel headstocks.

The Control Gear is so arranged that the motors are automatically controlled by the main hand levers. A cut-out switch is provided for completely isolating the motors when necessary.

A Ratchet Type Chain Grinder is self-contained with the machine.

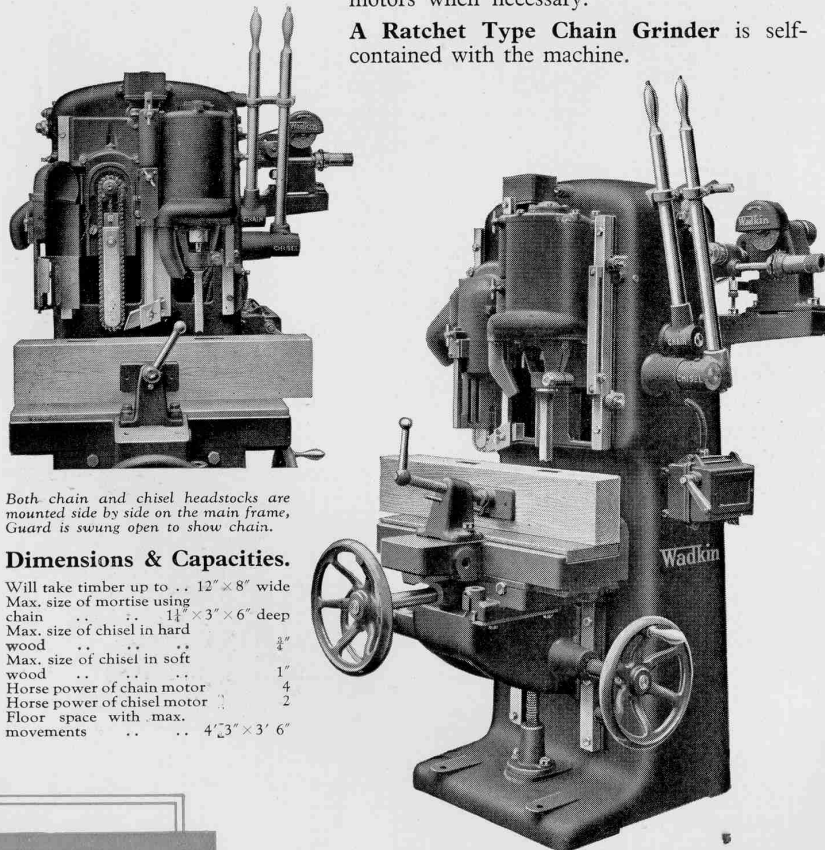

Both chain and chisel headstocks are mounted side by side on the main frame. Guard is swung open to show chain.

Dimensions & Capacities.

Will take timber up to .. 12" x 8" wide
 Max. size of mortise using chain .. 11" x 3" x 6" deep
 Max. size of chisel in hard wood .. 3"
 Max. size of chisel in soft wood .. 1"
 Horse power of chain motor .. 4
 Horse power of chisel motor .. 2
 Floor space with max. movements .. 4' 3" x 3' 6"

Wadkin

Chain and Chisel Mortiser Model M.A. Electric Chisel Mortiser M.G.

Model M.G.

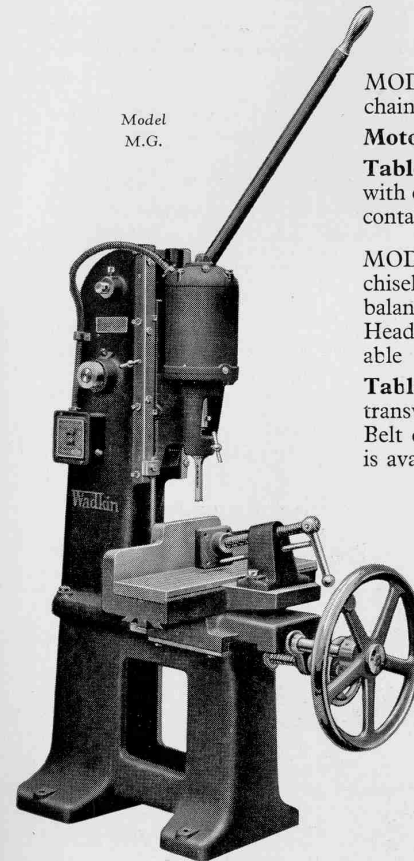

MODEL M.A. is quickly convertible to either chain or chisel.

Motor is built directly on the mortising spindle.

Table has longitudinal and transverse motions with cramp arranged to prevent work lifting. Self-contained ratchet type chain grinder is included.

MODEL M.G. is a strong serviceable tool for chisel mortising only. Chisel headstock is counter-balanced and incorporates totally enclosed motor. Headstock moves on heavy slideways and adjustable stops are provided.

Table has longitudinal and transverse motions. Belt driven machine is available.

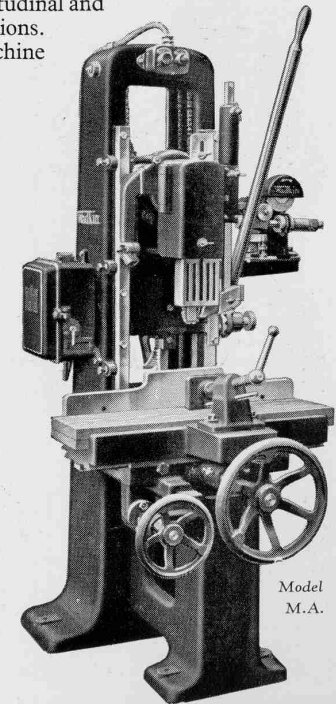

Model M.A.

Dimensions and Capacities.

	Model M.A.	Model M.G.
Will take timber ..	11" x 8"	9" x 7"
Max. size of mortise using chain ..	1" x 2 1/2" x 6"	—
Max. size of chisel in hard wood ..	3"	3"
Max. size of chisel in soft wood ..	1"	3/4"
Horse power ..	4	1
Floor space ..	4' 3" x 3' 6"	3' 2" x 3' 0"

Wadkin

Electric Tenoning Machine E.K.A.

This machine will tenon, scribe the shoulders and cut off to length at one operation. It will make tenons with unequal shoulders, angle tenons, and double tenons.

The Main Frame is of the swan neck type.

The Horizontal Headstocks are both arranged with a motor built in. The headstocks are independently adjustable vertically and horizontally. Hinged guards and brakes are provided on both headstocks.

Vertical Scribing Spindles are attached to the main headstocks and adjust with them. Independent vertical and horizontal adjustments are also provided. A separate motor is built into each head.

Cut-off Saw is mounted direct on a motor spindle, housed in the main frame at the rear of the heads.

Table is mounted on ball bearing rollers and provided with Fence. It is also fitted with a spring stop, across its full width, for loading narrow stuff. An adjustable dead stop also two adjustable quick acting lever cramps are provided.

Dimensions and Capacities.

Will admit timber up to ..	24" x 6"
Will cut tenons at one operation ..	6" long
Will trench or groove ..	24" wide
Will cross cut up to ..	24" x 2½"
Will admit between cramps and table ..	8"
Horse power for each tenoning and scribing head ..	2
Horse power for cut off saw ..	1
Floor space ..	7' 9" x 7' 0"

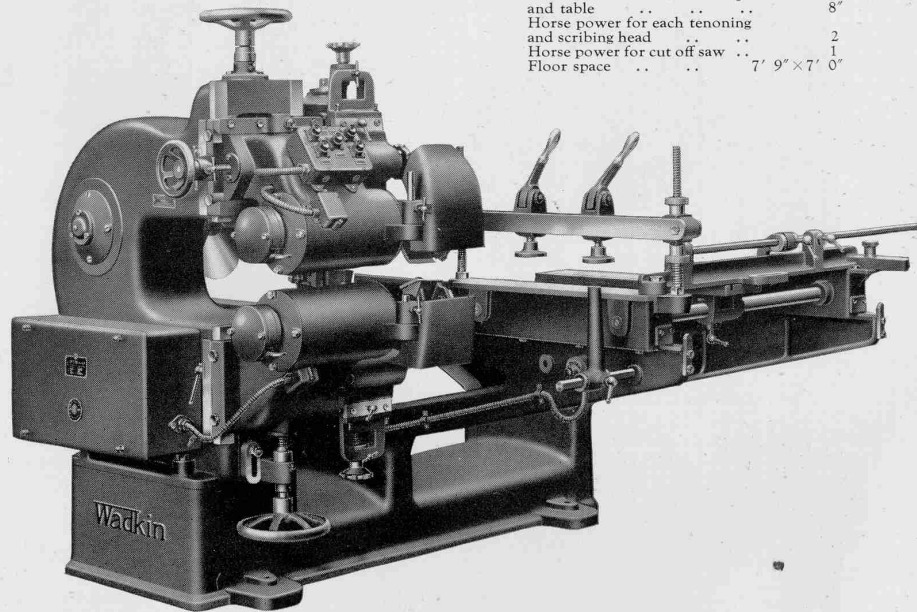

Electric Tenoning Machine E.H.A.

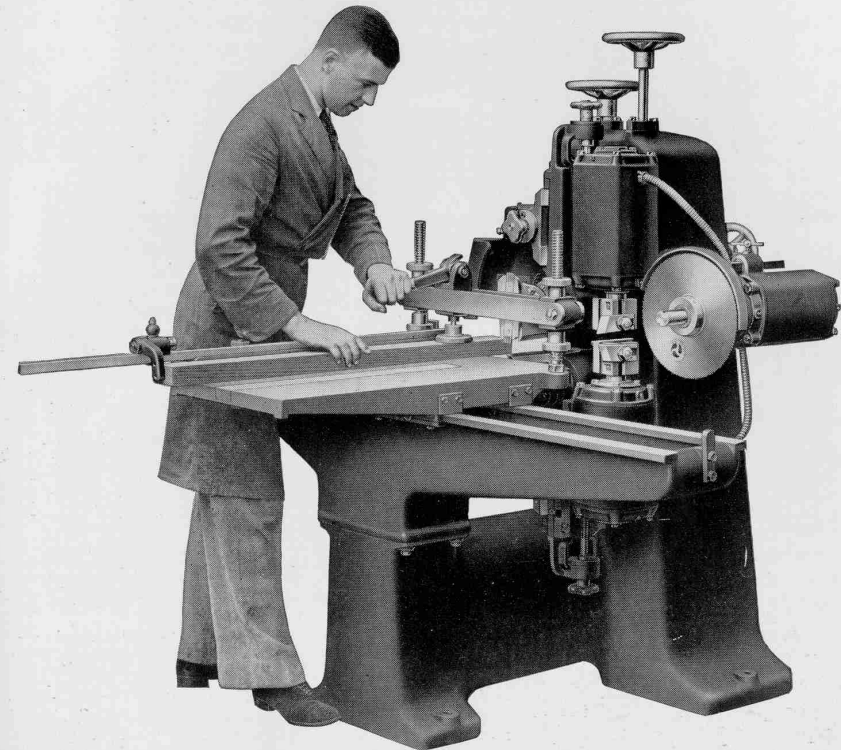

This handy compact tenoner is arranged to tenon, scribe the shoulders and cut off to dead length at one operation. It is completely modern in design with a built-in motor on each head.

Horizontal Headstocks are adjustable vertically, and can be adjusted either individually or together. Horizontal adjustment is also provided.

Vertical Scribing Spindles are each attached to the main headstock slides and are adjustable with them. In addition they have independent vertical and horizontal adjustment.

Cut-off Saw is mounted behind the cutterblocks. **Table** is mounted on ball bearing rollers, for easy movement.

Fence can be swivelled, and is provided with stops. A combined end and shoulder stop is included.

Dimensions & Capacities.

Will admit timber up to ..	12" x 4"
Will cut tenons at one operation ..	4½" long
Top cutterhead will rise above table ..	4½"
Size of table ..	2' 8" x 1' 4"
Horse power of motors for tenoning heads ..	1½
Horse power of motors for scribing heads and saw ..	1
Approx. floor space ..	5' 0" x 4' 6"

Wadkin

Wadkin

Sash and Door Cramping Machine S.D.C.

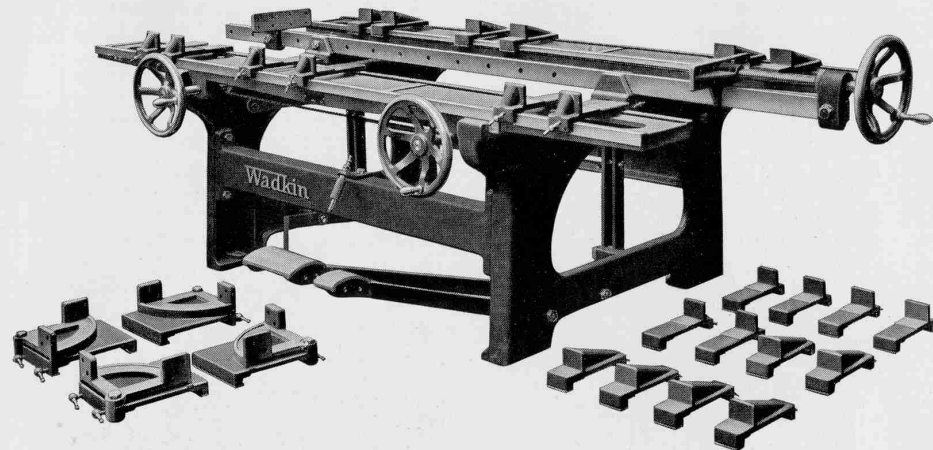

Framing—sashes, doors and a variety of built-up work can be cramped in this simple machine, in far less time than by ordinary hand cramps, and the work comes together perfectly square.

Foot levers operate the cramping mechanism which is so designed that the maximum pressure is applied just as the joint closes. Pneumatic buffer absorbs shock on opening.

Cramping rails and dogs are machined to ensure proper alignment.

End Cramp is carried on a heavy bar in the centre of the machine. Pressure is applied by handwheel and screw.

Corner Cramps can be supplied.

Dimensions and Capacities.

Largest capacity	8' 8" × 4' 3"
Smallest capacity	2' 1" × 6"
Floor space	10' 6" × 6' 4"

Note: When desired, this machine can be arranged to clamp material 8' 8" × 5' 6" wide.

Overhead Recessing Machine L.Q.

For recessing, boring, working outside or inside edges of straight or curved mouldings, chamfering, grooving, cutting housings, stair stringing, panel raising, slot mortising.

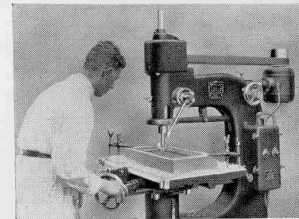

The machine is exceptionally useful for panel sinking operations as shown above.

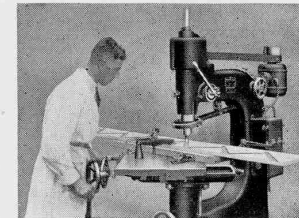

Cutting housings for string boards. Fixture in use dispenses with the need for marking out.

The Table has rise and fall also compound movements, including a swivelling movement. **The Cutter Spindle** revolves on heavy ball bearings and is carried in a balanced sleeve. The spindle may be securely locked at any position. Stops are provided for controlling the stroke of the cutter spindle.

The machine is driven by motor as shown and provision is made for keeping the belt at the correct tension. Belt driven machine is available.

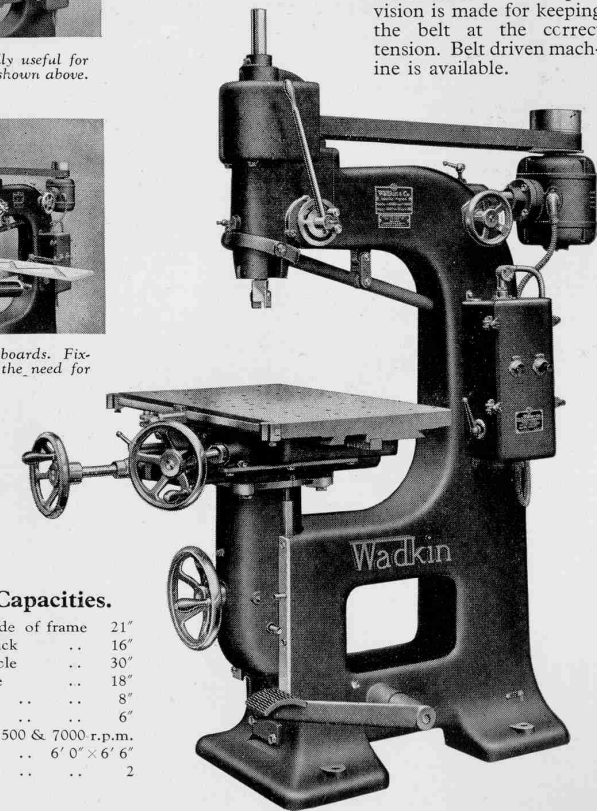

Dimensions & Capacities.

Centre of spindle to inside of frame	21"
Max. distance table and chuck	16"
Longitudinal traverse of table	30"
Transverse motion of table	18"
Rise and fall of table	8"
Rise and fall of spindle	6"
Spindle speeds	3500 & 7000 r.p.m.
Floor space	6' 0" × 6' 6"
Horse power	2

Electric High Speed Router L.S.

This machine has an exceptionally wide scope of working, including recessing, panel raising and sinking, fretwork, fluting, veining, etc.

Cutter Spindle Head has a motor directly on the cutting spindle. It has a vertical movement of 4" in vee slides operated by foot lever. Stops are provided to limit the depth of the cut.

Table rises and falls and former pin is arranged to disappear below the table by lever motion. Table has a removable plate for moulding.

Cutter Spindle is of heat-treated, nickel chrome steel, and runs on special precision high speed ball bearings. A built-in fan keeps face of the work clear of chips.

Spindle is provided with brake and locking device.

Frequency Changer necessary to obtain the spindle speeds of 18000 and 24000 r.p.m. is housed inside the base of the main frame.

Note. When preferred table may be arranged with compound movements.

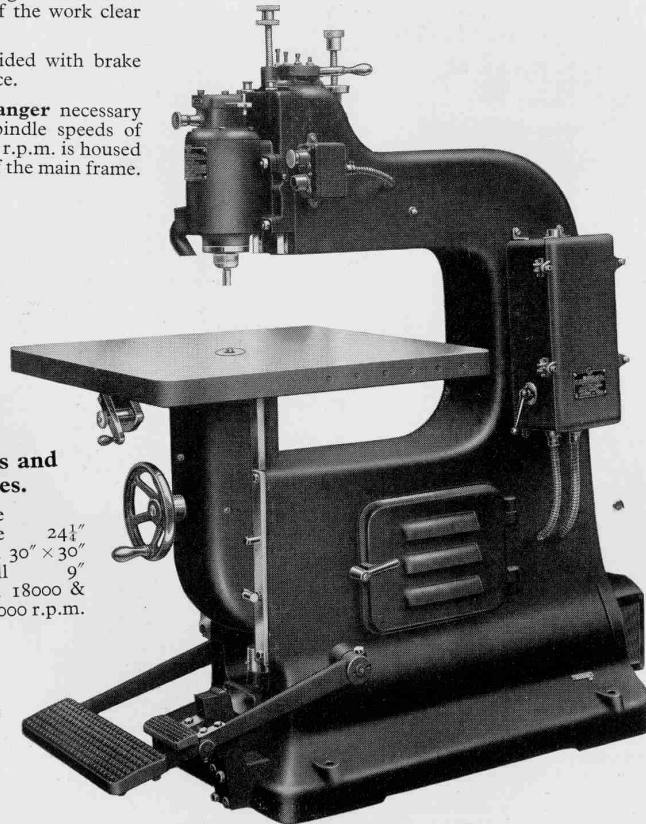

Dimensions and Capacities.

Centre of spindle to inside of frame . . . 24 1/4"
 Size of table . . . 30" x 30"
 Table rise and fall . . . 9"
 Spindle speeds . . . 18000 & 24000 r.p.m.

Electric Vertical Boring Machine L.M. Electric Horizontal Boring Machine L.J.

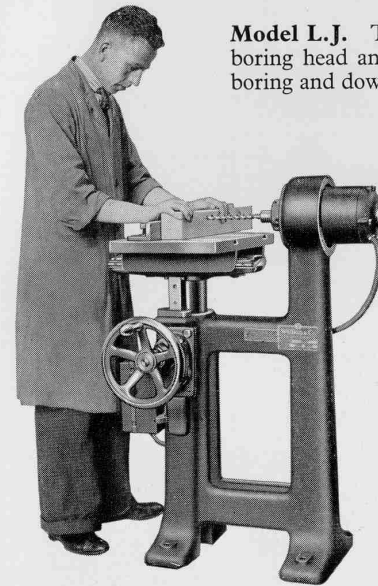

Model L.J. This type of machine, with its stationary boring head and sliding table, will be found ideal for end boring and dowelling on a production basis.

Boring Head embodies totally enclosed motor, and spindle is arranged to take a self-centring chuck.

The Table measures 20" x 14" and has easy movement on ball bearing rollers and renewable circular steel tracks. The table rises and falls and two fences are provided.

Adjustable Stops are fitted to give exact depth when repetition boring.

Dimensions and Capacities.

Will bore up to . . . 6" deep, 1" diameter
 Horse power of motor . . . 1
 Maximum distance of table below boring spindle . . . 6"
 Maximum distance from face of chuck to fence . . . 17"
 Chuck takes drills with parallel shanks up to . . . 17/32"
 Approx. spindle speed in r.p.m. . . . 2800
 Floor space . . . 36" x 24"

Model L.M. This is an extremely handy form of boring machine for general utility work.

Table rises and falls and is grooved to take fence.

Boring Head embodies motor and spindle is arranged to take a self-centring chuck.

Head rises and falls, the movement being actuated either by hand or foot.

Adjustable Stops are provided.

Dimensions and Capacities.

Will bore up to . . . 6" deep 1" diameter
 Horse power of motor . . . 1 1/2
 Will bore in centre of material up to a width of . . . 28"
 Boring chuck takes bits with parallel shanks up to . . . 3/8"
 Size of table . . . 20" x 15"
 Vertical motion of table . . . 16"
 Maximum distance between table and chuck . . . 24"
 Approximate spindle speed in r.p.m. . . . 2800
 Floor space . . . 20" x 31"

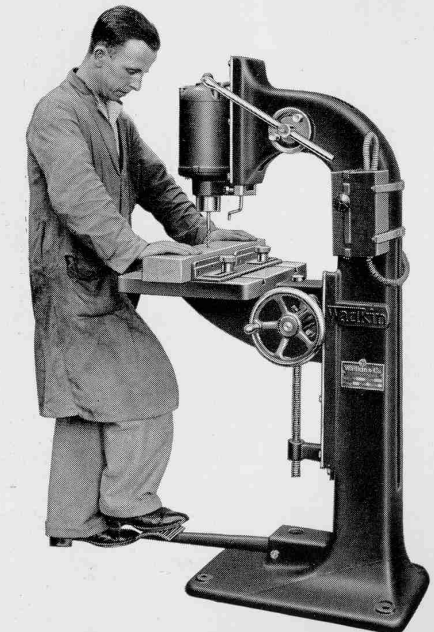

Electric Combined Disc and Bobbin Sander J.T.A.



Where floor space is limited or where the volume of work does not justify separate Disc and Bobbin machines, this combination machine will be found a most effective means of sanding both straight and radius work.

The Disc Spindle forms the shaft of an electric motor built into the head of the machine.

The Disc Work Table cants 45° below and 10° above horizontal. Table is grooved to receive a graduated fence.

The Bobbin is driven by a motor built on to the vertical spindle. It has reciprocating motion to ensure a smooth finish, and is adjustable in height. All gearing is totally enclosed.

The bobbin is of metal, with a unique method of locking, which both stretches and holds the paper.

The Bobbin Table cants 30° below and 10° above horizontal.

Dust Hoods are provided to both disc and bobbin and a disc press and two spare discs to facilitate renewing the abrasive paper.

Dimensions and Capacities.

Diameter of disc	30"	Size of bobbin table ..	2' 2" x 2' 1½"
Size of bobbin	3½" dia., 9½" long	Horse power, disc motor	4
Max. depth of material sanded with bobbin	8"	Horse power, bobbin motor	1
Size of disc table	2' 10" x 1' 5"	Floor space	5' 6" x 2' 10"

6" Open End Belt Sander G.S.

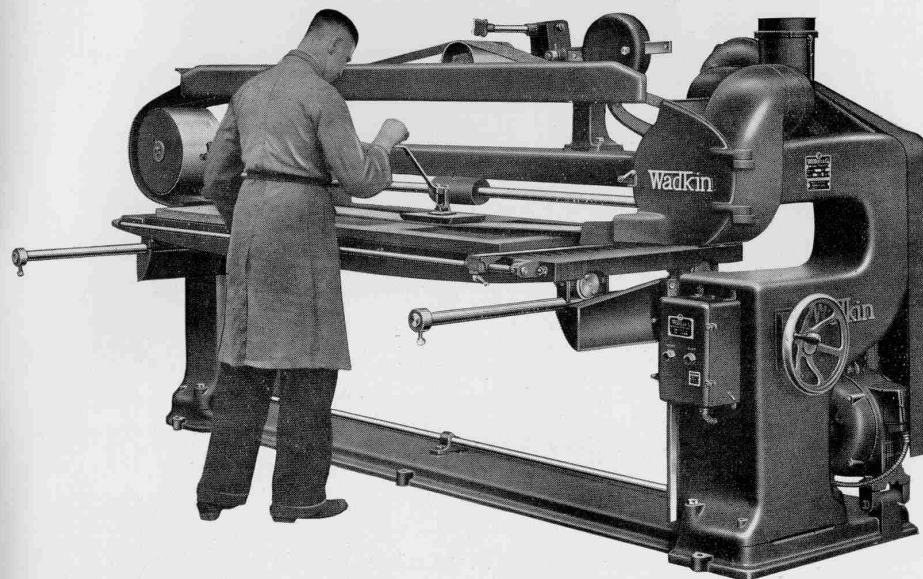

This machine provides one of the most efficient methods of sanding a wide variety of work. Its swan neck design enables it to sand exceptionally long lengths, whilst the large capacity between the table and the belt, give it a valuable scope of working on built up work.

The Drums and tension pulley are mounted on steel spindles running in ball bearings. **An Intermediate Band** is fitted to work between the sand belt and the travelling pressure pad.

The Travelling Pressure pad moves on ball bearing rollers and is counterbalanced.

The Table is of laminated construction to give lightness with rigidity and moves on ball bearing rollers. Stops are provided to limit the travel, or lock the table.

Table rises and falls by screw motion.

A Dust Hopper and fan are built on to the machine.

Electric Drive is by multiple vee belts from motor mounted on the machine base plate. Belt drive is available.

Dimensions and Capacities.

Max. depth between sand belt and table	1' 11"	Width of material sanded between columns ..	3' 6"
Any length can be sanded by passing under the arms, but not exceeding 2' 3" wide, 4½" deep		Size of table	8' 0" x 3' 0"
Length of material sanded between columns	7' 6"	Size of sand belt	22' 7" x 6"
		Floor space	11' 3" x 7' 0" (approx.)

Wadkin

Wadkin

6" Universal Belt Sander G.T.

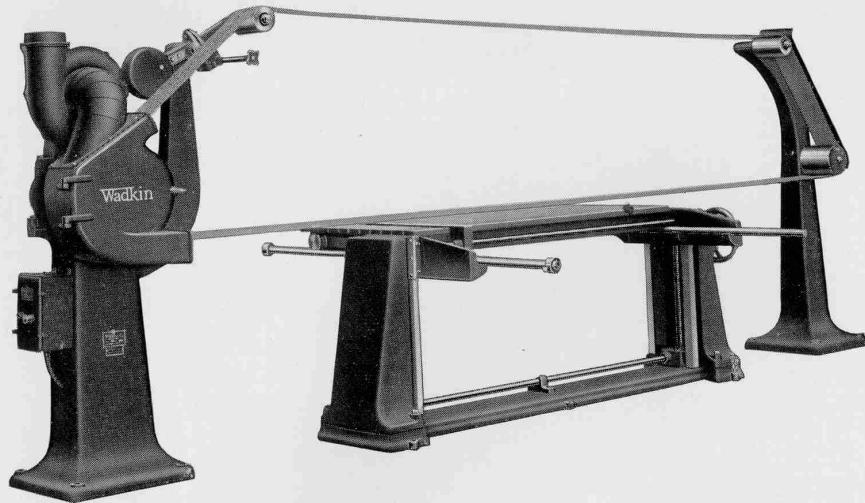

This machine, with the table separate from the columns can be arranged to carry belts of exceptional length. It is an ideal machine for the Cabinet Trade and will sand flat work, built up veneered cabinets, and many classes of curved or moulded work. A finish suitable for painting or polishing is obtained straight from the machine.

The Columns are independent of the table, and can be placed at any desired centres.

The Sander Drums and pulleys are on steel spindles running in ball bearings. Jockey and idler pulleys are of aluminium.

Tracking of the belt is by handwheel and screw motion operated from the front of the machine. Tensioning is by means of an adjustable weight. Felt covered hand pressure pad is provided.

The Table is of light yet rigid construction, and moves on ball bearing rollers, on circular steel runways. Stops are provided to limit the travel or lock the table. Table rises and falls by screws and fence is provided.

Dust Hopper and fan are built into the left hand column.

Electric Drive is by motor built into the left hand column, the sander drum being carried on the motor shaft. Belt drive is available.

Dimensions and Capacities.

Height from floor to sand belt	3' 4"	Length of sand belt at 16' 0" centres of columns ..	36' 4" x 6" wide
Max. depth between sand belt and table	2' 4"	Floor space at 16' 9" centres of columns	18' 0" x 7' 3"
Size of table	6' 0" x 3' 0"	Horse power of motor ..	4

6", 8" and 10" Electric Woodturning Lathes R.S.

This is a self-contained type of lathe, requiring no countershaft. It is particularly suitable for the needs of Engineers' pattern makers.

The Bed is of heavy design, with wide machined surfaces, and removable gap plate.

The Headstock Spindle runs in heavy ball bearings. It is screwed at both ends, and bored out morse taper at the front end. Four speeds are provided.

The Motor is carried inside the headstock and drives on to the spindle by belt also inside the frame.

The Tailstock is bored out and fitted with steel poppet controlled by handwheel and square thread screw. The front end is bored out morse taper same size as headstock. Centres are self-discharging. Tailstock is arranged with set over motion for taper turning.

Hand Turning Rest is supplied, but **Travelling Rack Slide** rest can be fitted.

Tripod and Stand can be supplied for outside turning.

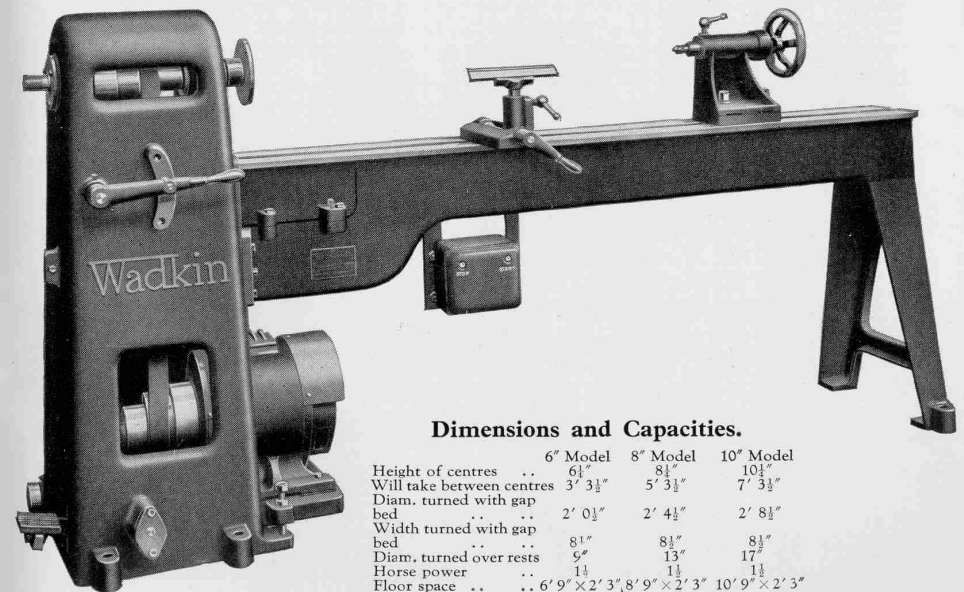

Dimensions and Capacities.

	6" Model	8" Model	10" Model
Height of centres ..	6 1/2"	8 1/2"	10 1/2"
Will take between centres	3' 3 1/2"	5' 3 1/2"	7' 3 1/2"
Diam. turned with gap bed	2' 0 1/2"	2' 4 1/2"	2' 8 1/2"
Width turned with gap bed	8 1/2"	8 1/2"	8 1/2"
Diam. turned over rests	6"	13"	17"
Horse power	1 1/2	1 1/2	1 1/2
Floor space	6' 9" x 2' 3" 8' 9" x 2' 3" 10' 9" x 2' 3"		

Wadkin

Wadkin

12" and 15" Electric Woodturning Lathes R.U.

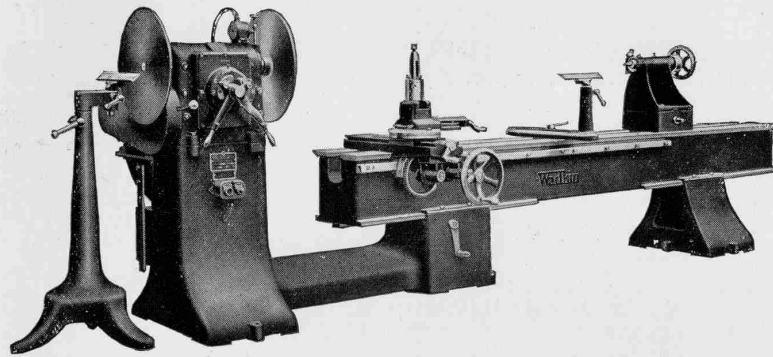

This is a machine for the heaviest and largest class of work. With a range of speeds varying from 98 to 1904 r.p.m., any class of turning either between the centres, or on the faceplates, can be done. It is self-contained and requires no countershaft.

The Bed is of heavy section with wide machined faces, and has a sliding motion away from the headstock by rack and pinion, to give any width of gap.

The Headstock Spindle runs on roller bearings, and is driven by a motor mounted on the headstock, driving on to a nine speed gear box by vee belts.

The spindle is screwed at front and back for faceplates, and bored out at front morse taper to take the centres.

The spindle is arranged with a lock, and motor cannot be started when this device is in operation.

The Tailstock is bored out and fitted with a steel poppet, controlled by handwheel and square thread screw. It is arranged with set over motion for taper turning. The front end is bored out morse taper. Centres are self-discharging.

The Hand Turning Rest is supplied or **Travelling Rack Slide Rest** can be fitted when required.

Outside Turning. A tripod stand complete with universal adjustable hand rest, also faceplate for turning work of large diameter can be supplied.

Dimensions and Capacities.

	12" Model	15" Model
Height of centres	12 1/2"	15 1/2"
Will take between centres with bed close up to the headstock	8' 3"	8' 3"
Maximum gap with sliding bed	2' 6"	2' 6"
Largest diameter that can be worked on inner faceplate	5' 6"	6' 0"
Diameter turned over tool rests	1' 7"	2' 1"
Floor space allowing for gap	14' 6" x 3' 3"	14' 6" x 3' 3"
Horse power of motor	3	3

Automatic Band Saw Filer and Setter H.D.

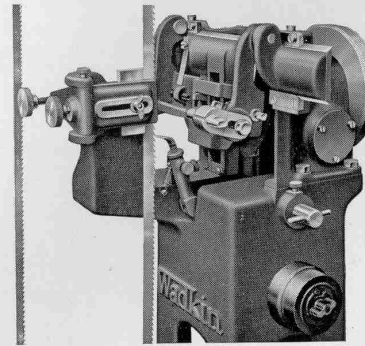

Close up view showing the machine set up for filing.

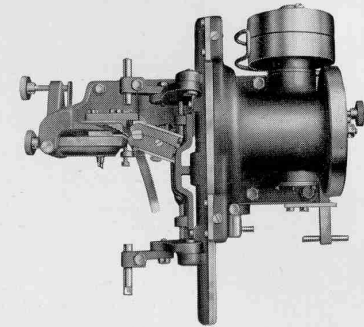

Plan view of the machine arranged for setting.

This machine will sharpen and set Band Saws quickly and efficiently.

Each tooth is sharpened and set to the correct depth and angle with accuracy and uniformity.

Filing. The action of the machine is obtained by the sliding carriage which carries the file, advancing to the saw and moving across the tooth.

At the end of the stroke the carriage falls away from the saw and returns to its original position. As the file returns, a feed pawl engages with the saw which is moved upwards ready for the next stroke. The file can be swivelled to any angle of tooth.

Setting is effected by means of a hardened steel die which is caused to swing across the teeth. The amount of set can be controlled.

Motor is self-contained with the machine. A belt driven model is also available.

Dimensions and Capacities.

Any length of saw can be handled.	
Maximum width of saw	2 1/4"
Will file up to	pitch
Floor space	3' 0" x 2' 0"
Horse power	1/4

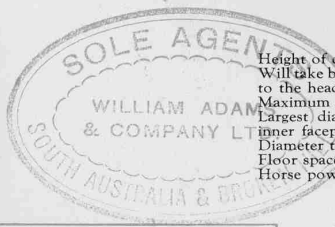
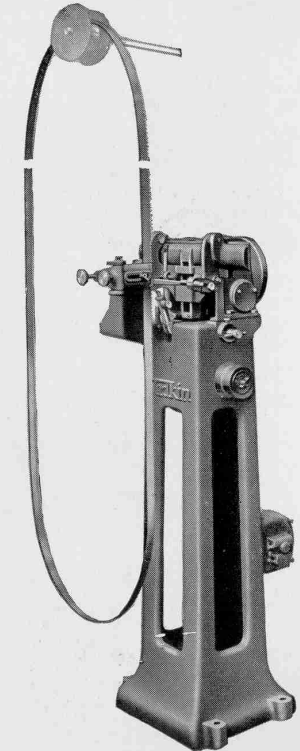

Wadkin

Wadkin

Automatic Saw Sharpening Machine H.C.

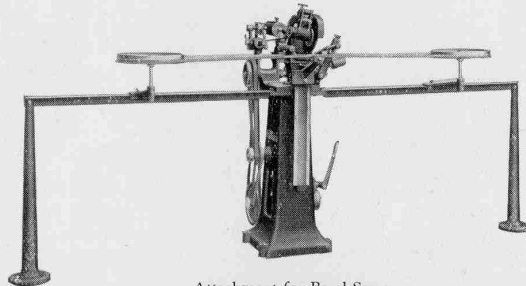
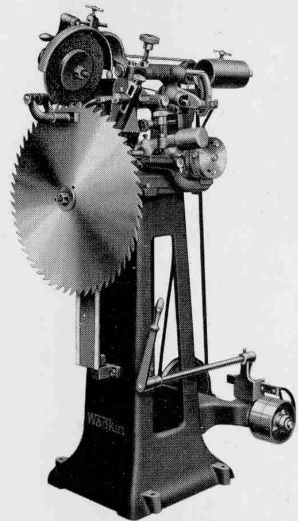

Attachment for Band Saws.

Band Saws from $\frac{1}{4}$ " to $2\frac{1}{2}$ " wide and up to 25' 0" long can be sharpened. Feed is entirely automatic.

This machine offers an efficient means of maintaining circular, band or frame saws in first class condition.

It will straighten and bevel top, bevel the face and gullet various shapes of teeth.

The Grinding Wheel Spindle is mounted in ball bearings. The grinding wheel has a patented pivoting motion to enable bevel topping to be done.

Two Rates of Automatic Feed are provided, namely 60 and 30 teeth a minute. Automatic feed may be disengaged and the feed operated by hand, if the pitch of the saw teeth is not uniform.

Saw Carrier can be swivelled for bevelling operations, and is adjustable vertically to suit different diameters of saws.

The Grinding Wheel is thoroughly guarded and a dust collecting hood included.

Drive. When electric driven, motor is self-contained with the machine. Belt drive is also available.

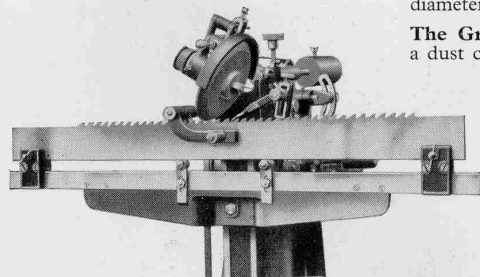

Attachment for Frame Saws.

Frame saws up to 6" wide, 6' 0" long can be sharpened on this attachment. Feed is automatic.

Dimensions and Capacities.

Will take circular saws .. 8" to 54" diam.
 Horse power I
 Floor space (without saws) .. 3' 6" x 2' 3"

Plane and Moulding Iron Grinder N.B. and N.C.

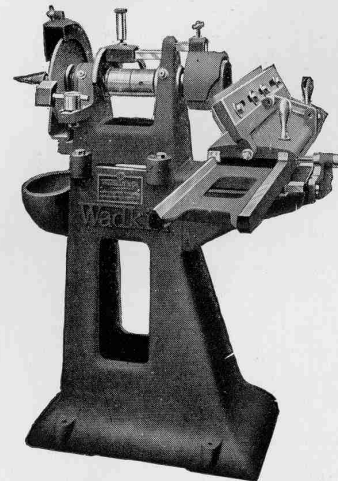

Slide Covers have been removed in above illustration.

This machine is designed to grind thick and thin planing machine cutters, moulding cutters, chisels, gouges, etc.

The Spindle runs in ball bearings. **The Carrier Vice** holding thick or thin knives, machine irons, slides on machined ways and is adjustable to give any required bevel on the iron. It also has horizontal movement to give the feed as the iron is ground.

A Water Tank is fitted and grinding wheels are thoroughly guarded.

Drive. When electric driven, motor is carried on the main frame as shown. Belt drive is also available.



A Saw Sharpening and Gulleting Fixture can be supplied for use on this machine, providing an economical and efficient means of maintaining in good condition any circular saw from 9" to 38" diameter.

Dimensions and Capacities.

	26" N.B.	30" N.C.
Will take planing cutters	26"	30"
Max. size grinding wheel	10" x 1"	10" x 1"
Max. size of cup wheel	6" dia. 4" wide	6" dia. 4" wide
	$\frac{3}{4}$ " thick wall	$\frac{3}{4}$ " thick wall
Horse power	$\frac{1}{2}$	$\frac{1}{2}$
Floor space	3' 0" x 6' 4"	3' 0" x 6' 8"

Index.

	<i>Pages</i>
Band Sawing Machines - - - - -	15
Band Saw Filer and Setter - - - - -	37
Belt Sanders - - - - -	33-34
Boring Machines - - - - -	29, 31
Chain and Chisel Mortisers - - - - -	24-25
Chisel Mortiser - - - - -	25
Circular Saw Benches - - - - -	10-14
Combined Disc and Bobbin Sander - - - - -	32
Combined Planing and Thicknessing Machines - - - - -	22
Cross Cut Saws - - - - -	4-9
Cramp (Sash and Door) - - - - -	28
Dimension Saw - - - - -	14
Disc Sanders - - - - -	32
Edging Saw - - - - -	12
Grinding Machine - - - - -	39
Jointing Machines - - - - -	18-19
Lathes - - - - -	35-36
Mortising Machines - - - - -	24-25
Moulders - - - - -	16-17
Panel Planers - - - - -	20-21
Pendulum Cross Cut Saws - - - - -	9
Planing Machines - - - - -	16-22
Planing and Moulding Machines - - - - -	16-17
Plane Iron Grinders - - - - -	39
Recessing Machine - - - - -	29
Roller Feed Saw Benches - - - - -	13
Router - - - - -	30
Sanders - - - - -	32-34
Sash and Door Cramp - - - - -	28
Saw Benches (Circular) - - - - -	10-14
Saw Setters - - - - -	37
Saw Sharpeners - - - - -	37-38
Spindle Moulders - - - - -	23
Straight Line Edger - - - - -	12
Surface Planers - - - - -	18-19
Tenoners - - - - -	26-27
Thicknessers - - - - -	20-21
Trenching Machines - - - - -	4, 5, 7
Wood Grinders - - - - -	32

STORES OFFICER,
No. 2 Explosives & Filling Factory,
Salisbury, South Australia.