

190

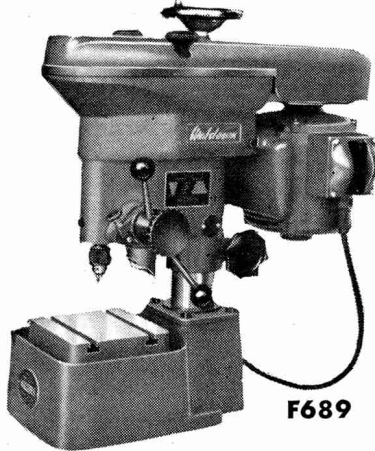

ELECTRIC BENCH DRILLS



F689

For high production drilling

F689—WALDOWN 1/4" CAPACITY BENCH DRILL

A high speed precision machine, with a range of six speeds. 12,000, 10,750, 6,500, 6,000, 5,800 and 3,300 r.p.m.

Entire head can be raised and lowered 4 in. Vertical travel of quill, 2 in.

Throat clearance, 5". Maximum working distance between chuck and top of base, 6". Approx. overall height with head fully raised, 28 1/2".

Supplied with 1/2 h.p., 415 volt, 3 phase motor.

F690—WALDOWN 1/2" DRILLING MACHINE

The stroke or travel of the quill is 4". Power from the operator is transmitted by a three-handle capstan lever.

A clearly graduated dial on the left side of the head is friction held on to the pinion spindle. This permits quick and easy setting for ascertaining the depth of hole being drilled.

A quick-acting drill stop is provided on the right side of the head. This is actuated by a star hand wheel in the centre of the capstan.

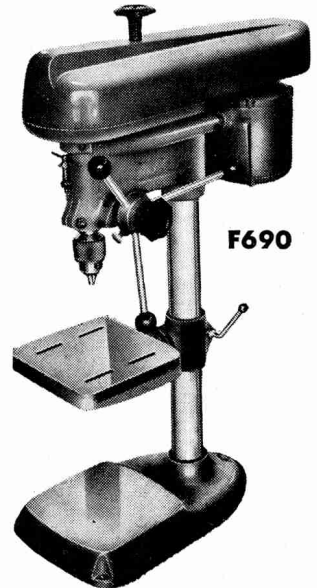

F690

F691—MACBRO BENCH DRILL 1/2" CAPACITY

Ball-bearing with specially designed bronze driving sleeve. Drills to the centre of a 14" circle.

Fitted with half-inch Jacobs pattern chuck as standard equipment or No. 1 Morse tapered spindle can be supplied alternatively.

Easily adjustable depth stop.

Calibrated rotary dial which is adjustable for determining depth of drilling.

Adjustable clutch on cross shaft is an aid to sensitive drilling. Drill has vertical travel of 3 1/2".

The table can be rotated and tilted to any angle in the full 360°. The table can also be removed from its bracket and jigs mounted quickly in its place. Four slots for bolting purposes are provided.

Motor 1/2 h.p. supplied in either single or 3 phase, complete with starter and flex.

Five speeds — 360 to 5,000 r.p.m.

Distance from chuck to base is 15". Table diameter, 10".

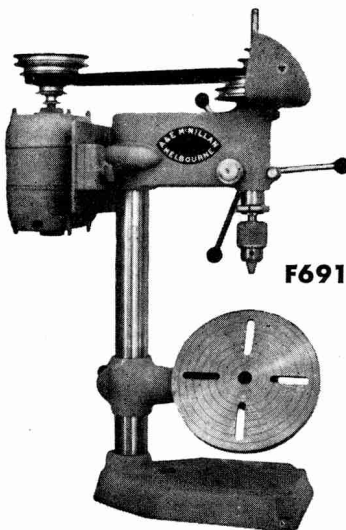

F691

F692—WALDOWN TYPE 2M DRILLING MACHINE

SPECIFICATIONS

Capacity, 7/8". 3/4 H.P., 3 phase, 415 V. motor. Fitted with intermediate drive. Nine drilling speeds: 3,000, 2,000, 1,800, 650, 570, 480, 320, 280, 150 R.P.M.

Swivelling and tilting table, raised and lowered by smooth rack and pinion action. 3" dia. ground steel column.

Throat clearance: 7 1/2".

Spindle to table fully lowered, 28".

Spindle to machined face of base, 48".

Length of quill stroke, 4".

Overall height, 67".

A smooth-acting table lifting and lowering action is provided through a rack and pinion, worm and wheel mechanism. The whole can be swung in a complete circle.

A large 3 1/4" dia. easily read depth dial is fitted which is held in position by a pre-loading friction spring.

Equipped with the Waldown adjustable positive depth stop.

Fitted with a No. 2 Morse Taper Socket Spindle inbuilt inside the quill for greater stability.

Ball-bearing equipped as standard, but can be fitted with Timken taper roller bearings for special applications.

An "O" ring is fitted above the bearing housing of the quill to minimise jar on the back stroke.

Fitted with a substantial 12" x 12" table embracing two machined "T" slots (4 1/4" centres) and coolant trough. Table is tilting.

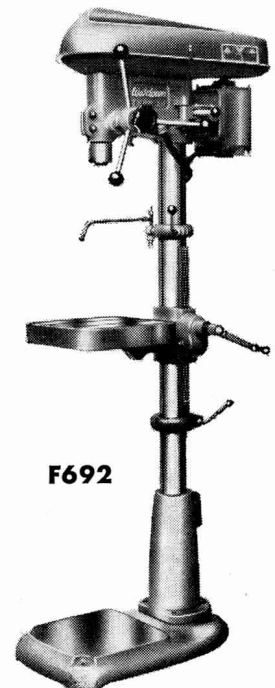

F692

F693—UTILITY RADIAL DRILLING MACHINE
1/2" CAPACITY IN MILD STEEL
1" IN SOFT METAL AND WOOD

This versatile Drilling Machine has a radial arm extension of 20 1/2". Holes may be drilled anywhere and at any angle within a 41" circle. (Special arm to 51" available.)

It is extremely useful in cases where the depth of throat is important. May be fitted with a chuck or No. 2 Morse Taper with chuck and arbor.

Although it is normally of 1/2" capacity it may be used for larger drills in soft metal or wood.

Standard speed range is 4,000, 2,000, 1,000 and 500 r.p.m., but by fitting an intermediate drive the range may be increased to nine, from 170 r.p.m. to 5,500 r.p.m.

Normally powered by a 1/2 h.p. three or single phase motor, but may be increased as desired. On-off switch is mounted in head readily accessible to the operator.

Available as Bench or Floor Model.

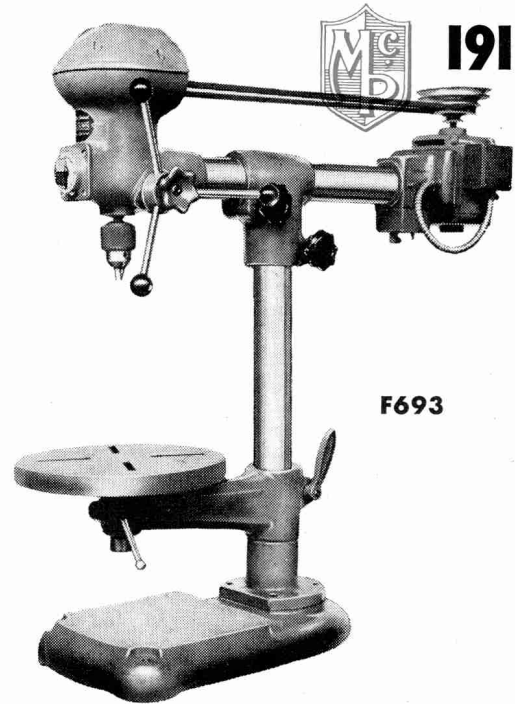

F693

F694—TOUGH 1/2" MOTORISED DRILLING MACHINE

The main spindle, of alloy steel, passes through a driving sleeve attached to the pulley, the actual drive being by splines cut into the spindle.

Two ball-races carry this spindle in the barrel, and two more which carry the pulley give the spindle further support.

The barrel can be locked for routing and a graduated stop is provided for drilling to specified depth.

The table revolves for quick alignment of work, and is slotted for holding down work or jigs.

The motor is mounted on a hinged bracket for quick adjustment of belt tension. Four-step motor pulley is supplied. A 1/3 h.p. motor is recommended.

Models available to suit Jacobs or other popular chucks also to take No. 1 Morse or No. 2 Morse taper shanks.

Capacity — 0 to 1/2". Drills to centre of 12 3/4" circle. Drilling depth — 4". Distance chuck to table — 10 1/2". Diameter chuck to base — 17 3/4". Table — 11 1/2" diameter. Base where machined — 9" x 9". Approximate speeds, with 50 cycle motor, 4,300, 2,300, 900 and 475.

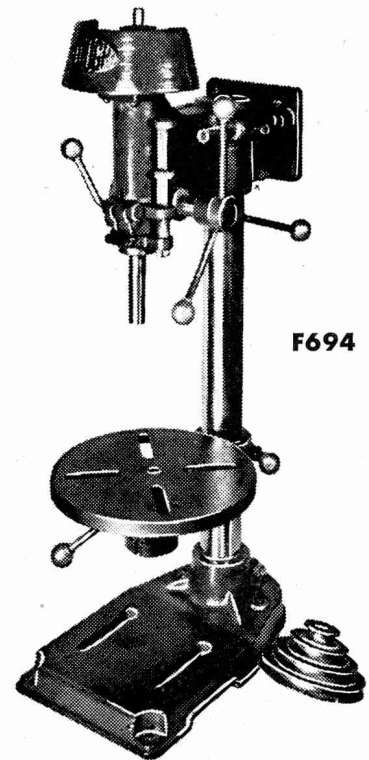

F694

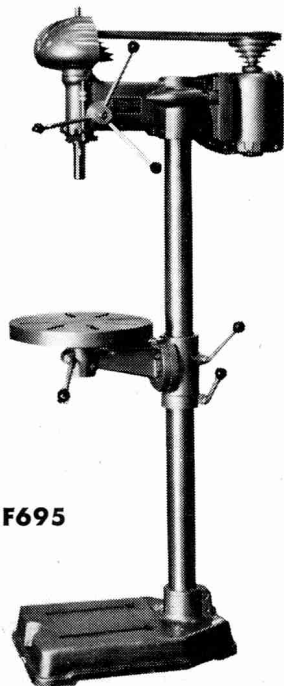

F695

F695—
THRENOW
7/8-in. PEDESTAL TYPE
DRILLING MACHINE

Threnow Bench Type Drilling Machine incorporates the same basic features as the Pedestal Drilling Machine.

A compact and robust fingertip-control drill that ensures accurate working and effort-less operation!

Threnow Drilling Machine Slow Speed Attachment for both Pedestal and Bench Type Drills. Is rigidly designed, running in ball races, for easy mounting on top of the column. By fitting this Attachment a wide variety of Spindle speeds is available. Slow speed, 110 r.p.m. Standard Machine No. 2 Morse Taper Spindle. Can be supplied with No. 3 Morse Taper Spindle if required.

SPECIFICATIONS

Vertical Travel of Quill	4 1/4"	3rd Speed	1,000 r.p.m.
Centre of Drill Spindle to Column . .	9 1/4"	4th Speed	585 r.p.m.
Spindle Speeds —		5th Speed	290 r.p.m.
1st Speed	2,550 r.p.m.	Base to Spindle (Pedestal Type) . .	3' 10"
2nd Speed	1,590 r.p.m.	Base to Pedestal (Bench Type) . .	1' 10"



F696—“HERCUS” 4A HIGH SPEED DRILLING MACHINE

A modern, powerful machine suitable for both production and jobbing work and incorporating the higher speeds and robust construction necessary to achieve performance from present day cutting tools.

SPINDLE DRIVE is taken direct from a flange mounted motor through a nine speed gearbox giving a range of speeds from 73 to 1,065 r.p.m. Speed change is effected by a single lever with a direct reading speed chart on the front of the machine. Lubrication is by an oil bath in the floor of the gearbox from which oil is circulated to all gears and bearings through a built-in pump.

AUTOMATIC FEED is positively driven from the gearbox through a worm and wormwheel. Feed engagement is made by a simple outward movement of the pilot levers. An automatic depth stop is provided to disengage the power feed at any desired position. An overload safety clutch on the worm shaft protects the machine against damage in the event of accident or over-running.

HAND FEED is obtained direct through the star wheel for normal drilling or through the hand wheel for fine or heavy duty feeding.

Drilling Capacity in Steel	1 1/4"	Working Surface of Base	16 1/4" x 15 1/2"
Spindle Taper (Morse)	No. 3	Dia. of Column	6"
Distance, Column to Centre of Spindle	12 1/2"	Speeds	9
Travel of Spindle	8"	Speed Range	73-1,065
End of Spindle to Table Surface (Max.)	23 3/4"	Feed Range005, .01, .02
End of Spindle to Table Surface (Min.)	3 3/8"	Motor	2 1/2 H.P.
End of Spindle to Base	41 1/8"		

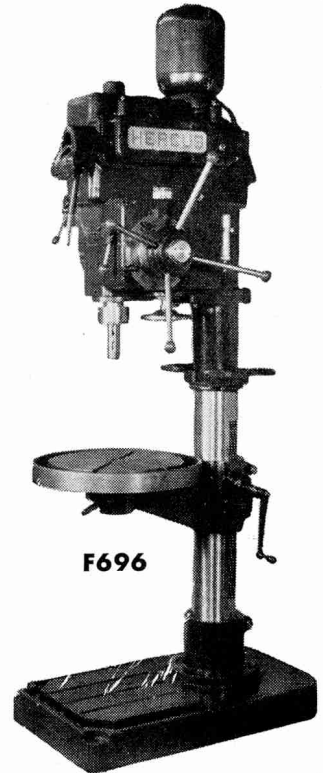

F696

F697—ELLIOTT PROGRESS PILLAR DRILLING 3A AUTO-FEED DRILL

- ★ Five spindle speeds—110 to 1,780 r.p.m. or optionally 70-1180 r.p.m. These ranges apply to either 50c or 60c supply.
- ★ Ten speed model also available—70 to 1780 r.p.m. using 2-speed motor.
- ★ Patented power feed mechanism—feed rate .004" per spindle revolution.
- ★ Adjustable depth stop and automatic feed trip.
- ★ Spindle return by spring adjustable for tension.
- ★ Hinged motor plate for quicker, easier speed change—spring loading ensures correct belt tension.

- ★ Large rectangular tee slotted table.
- ★ Spindle bored No. 3 Morse taper.
- ★ Large diameter quill.

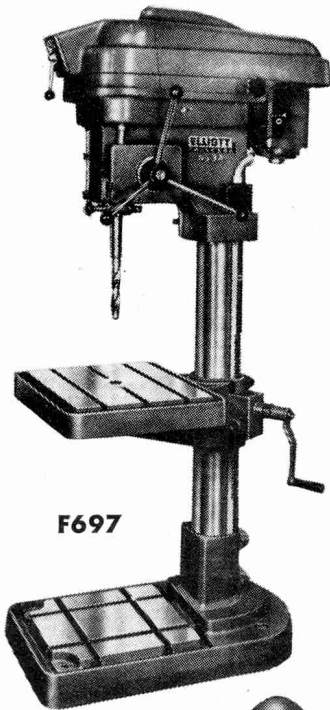

F697

Drilling capacity in steel	1 1/4"
Table (circular 17 1/2" dia.)	22" x 18"
Spindle travel	6"
Column diameter	4 3/4"
Maximum spindle to table	23 1/2"
Maximum spindle to base	41 1/2"
Spindle centre to column outside diameter	10"
Feed rate	0.004"/rev.

5 spindle speeds—

1400 r.p.m., 50 cycle motor	110, 210, 440, 1010, 1780 r.p.m.
960 r.p.m., 50 cycle motor	70, 140, 290, 670, 1180 r.p.m.
1700 r.p.m., 60 cycle motor	110, 210, 440, 1010, 1780 r.p.m.
1140 r.p.m., 60 cycle motor	70, 140, 290, 670, 1180 r.p.m.

10 spindle speeds—

960/1400 r.p.m., 50 cycle motor	70-1780 r.p.m.
1140/1700 r.p.m., 60 cycle motor	70-1780 r.p.m.
Power of motor	1 1/4 h.p.

STANDARD EQUIPMENT. Vee belts, 3-phase electrical equipment, drill drift, operator's handbook.

EXTRA EQUIPMENT. 3/4" capacity chuck and No. 3 M.T. shank, Victoria plain or swivel base vice, chuck guard, no volt release and current overloads. 60-S..9/1/2b..

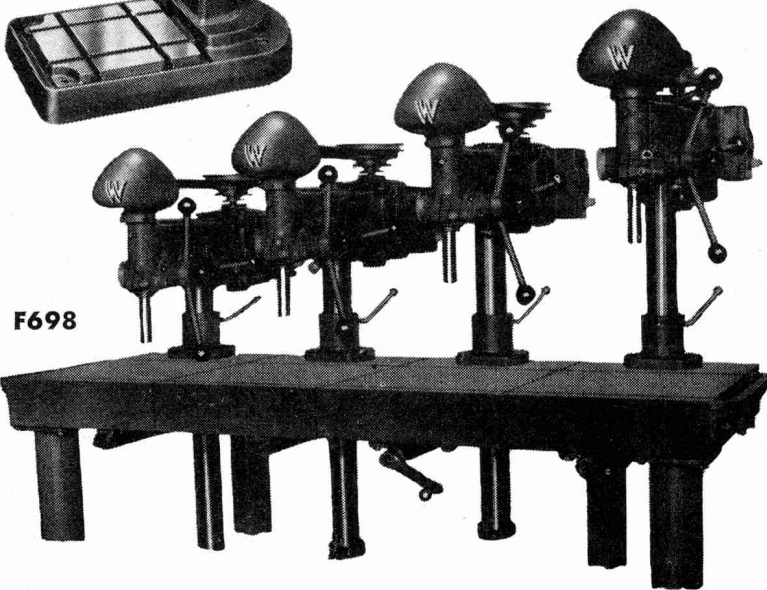

F698

F698—WALDOWN MULTIPLE SPINDLE FLOOR MODEL DRILL

1/2" Waldown. Multiple and counterbalanced drill heads which can be raised or lowered on the column, mounted on a common base.

Full particulars on request.

Nine spindle speeds,
from 88 to 1,450
r.p.m.

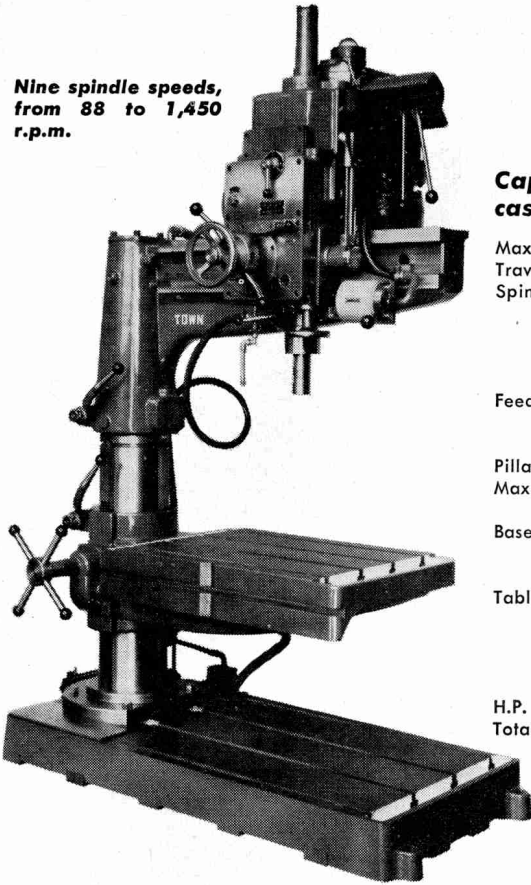

TOWN 193

42 in. Radius High Speed Drilling Tapping and Studing Machine

Capacity drilling, 1 1/4" from the solid in mild steel and 1 1/2" in cast iron. Tapping, 3/4" Whitworth in mild steel and cast iron.

Maximum Radius of Drill Spindle	3' 7"
Traverse of Saddle along Arm	2' 9"
Spindle — Diameter in Smallest Part	1 1/4"
— Bored to Morse Taper No.	3
— Feed Traverse, Hand and Self-acting	9 1/2"
— Speeds — Number	9
— Speeds — Range, R.P.M.	88 to 1,450
Feeds — Number of Positive	3
— Range — Revolutions per inch	80 to 200
— Inches per Revolution013" to .005"
Pillar Diameter	9"
Maximum Distance — Spindle to Baseplate	3' 7 1/2"
— Spindle to Table	2' 4 1/2"
Baseplate — Depth	5 1/2"
— Working Surface — Length	3' 6"
— Working Surface — Width	2' 4"
Table — Vertical Adjustment	17"
— Working Surface — Top Length	3' 0"
— Working Surface — Top Width	2' 0"
— Working Surface — Side Length	3' 0"
— Working Surface — Side Depth	6"
H.P. of Spindle Motor	2
Total Height Floor to Top of Spindle	7' 6"

Alternative range of speeds, 60 to 1,000 r.p.m., can be supplied. Unless otherwise stated, the standard range of 88 to 1,450 r.p.m. will be supplied.

SPINDLE DRIVE is from 2 h.p. constant speed reversing motor, underslung at rear of the saddle. Stop, start and reverse are operated by single lever.

SADDLE is of box form, accurately bedded to arm on ample bearing surfaces. Easy traverse on ball bearings is operated by handwheel

through steel rack and pinion, with efficient lock. All mechanism is totally enclosed and all spindle controls are placed conveniently on the saddle.

ARM, of sturdy design, revolves on pillar on ball bearings, and is locked by lever. It can be swung in a complete circle except for cable interference.

PILLAR, of strong proportions, is accurately ground to receive the table. Steel rack is fitted for table adjustment.

Other sizes of TOWN drills also available.

Fully illustrated leaflets available on request.

DENBIGH 20" AND 24" HIGH SPEED DRILLING MACHINE

Rack-Geared, Worm and Lever and Automatic Feeds.

Direct Motor Drive, drills up to 1 1/4" in steel.

Worm and Worm Wheel always in gear.

The change from Wheel or Automatic Feeds to Lever Feed, or vice versa, is made by the simple movement of levers.

Drills to centre of	20" or 24"
Diameter of Spindle	1 5/16"
Feed of Spindle	9"
Hole in Spindle	No. 3 Morse
Diameter of Table	16"

Ask for full specifications.

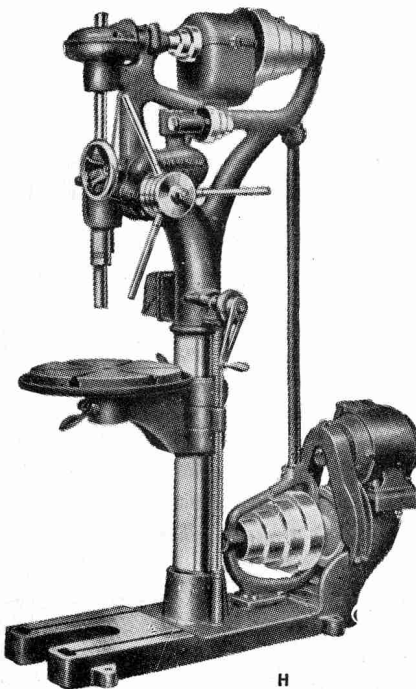

H

194



TAPPING MACHINES

WALDOWN SENSITIVE TAPPING MACHINE

TYPE 1 MT

Capacity 2BA - 3/16"

Tapping speeds: 750, 1,500, 3,000 revolutions per minute

Spindle is light in weight thus reducing inertia to a minimum — which permits rapid reversing of the tap. No clutches, gears, or mechanism, merely a double friction cone. A quick acting lift table and adjustable stop is provided for rapid production. This tapper used in conjunction with the "Waldown" Type NH High Speed Sensitive Drilling Machine provides the ideal combination for solving the high production problem of small tapped holes.

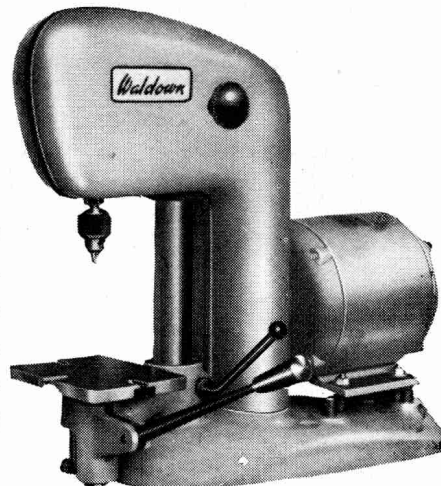

Supplied complete with 1/3rd h.p., single phase, 230 volt. Alternatively 1/2 h.p., single phase or 1/2 h.p., 3 Phase, 415 volt motor. (Complete with switch.)

HULLER TAPPING AND THREADING MACHINE

Huller Tapping and Threading Machines meet the highest requirements of modern mass production. Their outstanding feature is an entirely automatic tapping or threading operation. The reversing of the spindle is effected electrically by means of a control switch operating a reversing motor. With these machines it is possible to make full use of modern high-speed cutting tools and thus to increase production to the maximum of their capacity.

MODEL	1	2	3	5
Max. Dia. Thread Cut in Steel .. about in.	3/16	9/16	1/2	1 3/16
Max. Dia. Thread Cut in Steel .. about in.	3/16	1/2	9/8	1 1/2

Full Specifications on Request.

WALDOWN MODEL MCT, 3/8" TAPPER-AUTOMATIC WITH CONTROLLED PITCH

Capacity 3/8" in Mild Steel.

An extremely smooth operating Tapping Machine capable of single or multi-hole tapping.

Reversing is effected by electrically operated contactors controlled by micro switches actuated by top and bottom cams.

Predetermined depth adjustment is made by merely setting one cam.

Controlled Pitch Unit may be supplied with interchangeable lead screws and nuts for controlling the tapping of difficult or thin materials, ensuring the forming of an accurate thread.

The machine has an entirely automatic cycle and can be electrically interlocked into an automatic set-up.

Combines also with Waldown Multi-Spindle Drilling Machines for mass production drilling and tapping.

Also available in Floor and Bench Models.

